

WIDIA™ Solid Carbide End Mills
High-Speed Trochoidal Milling

WIDIA ™

A close-up, high-angle photograph of a metal cutting process. A large, dark metal tool is positioned above a workpiece. Several blue-colored metal shavings are being ejected from the cutting zone, indicating a high-speed machining process. The lighting is dramatic, highlighting the metallic surfaces and the bright blue of the chips.

WIDIA™ Means Complete Quality

As an innovator for more than 80 years, the WIDIA Products Group has been designing and manufacturing metalcutting products that make customer machining processes more efficient and effective.

With thousands of products in our portfolio, the WIDIA Products Group offers competitive advantages that will enhance your productivity and bolster your profitability.

To learn more, contact your local Authorised WIDIA Distributor or visit www.widia.com.

Trochoidal Milling

Trochoidal Milling	2-8
WIDIA Milling Portfolio Overview	9
High-Performance Solid Carbide End Mills	10-53
Tooling Systems	54-77
SAFE-λOCK™ Shrink-Fit Toolholders	54-62
HydroForce Toolholders	64-77
Technical Information	78-79
Price Lists	80-83
Icon Legend	84
Material Listings	85

■ Conventional Slotting

- Full slotting limitations:
 - Usually not more than $a_p = 1 \times D$.
 - Conventional and climb milling at the same time.
 - High heat development on the tool and on the workpiece.
 - Difficult chip evacuation.
 - High radial forces.
- This means:
 - No constant chip thickness.
 - Low MRR.
 - Surface quality from the left to right side are different.
 - Limited tool life.
 - High power and torque requirements for the machine.

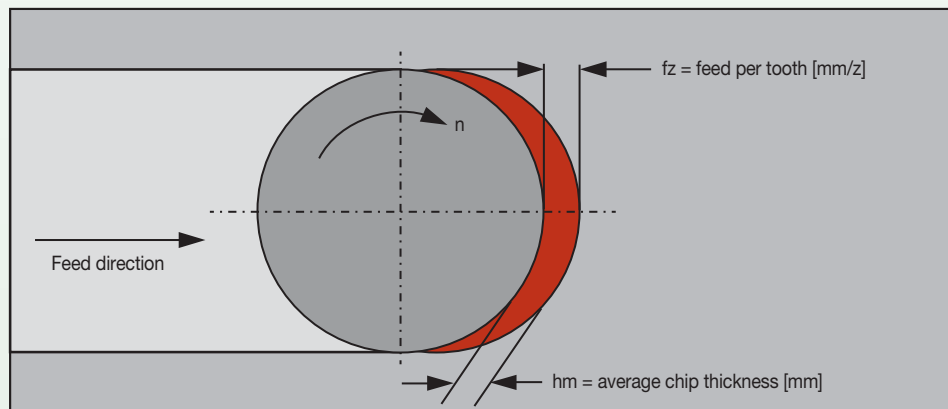

■ Trochoidal Milling

- What is trochoidal milling?
 - Static trochoidal milling
 - Dynamic trochoidal milling
- What benefits do I get from trochoidal milling?
- What do I need?
- Tools for trochoidal milling
- How to

■ ae and Chip Thickness

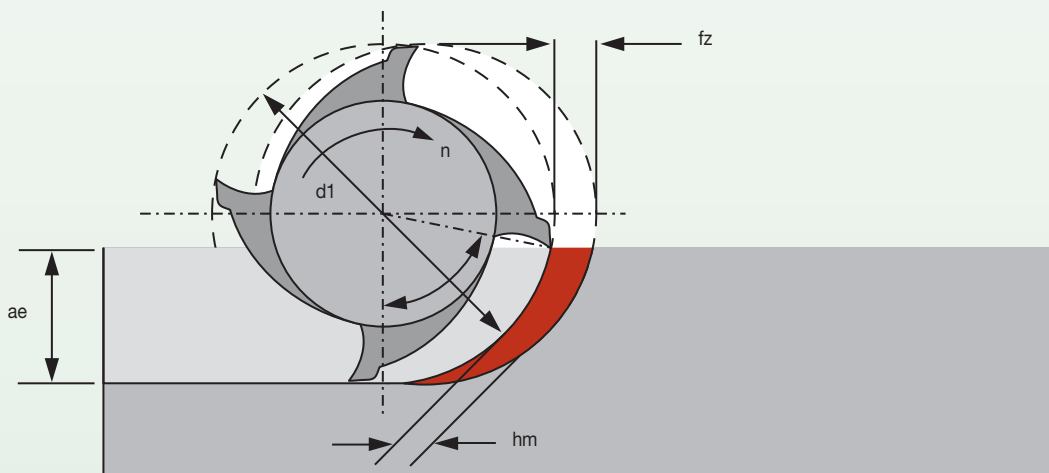

To calculate average chip thickness:

$$hm = fz \cdot \left(\sqrt{\frac{ae}{d_1}} \right)$$

Simplified formula for shown application and 90° angles on the tool.
The chip thickness defines the load on the cutting edge.

■ ae and Chip Thickness

chip thinning effect		
ae	programmed feed (fz)	chip thickness (hm)
100%	0,15mm	0,1mm
50%	0,15mm	0,1mm
40%	0,15mm	0,09mm
20%	0,15mm	0,07mm
10%	0,15mm	0,046mm

The chip thickness needs to be compensated by feed.

100%

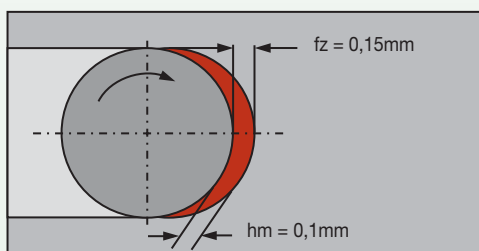

50%

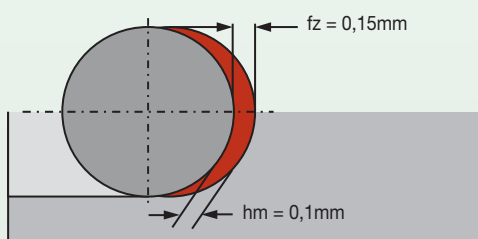

40%

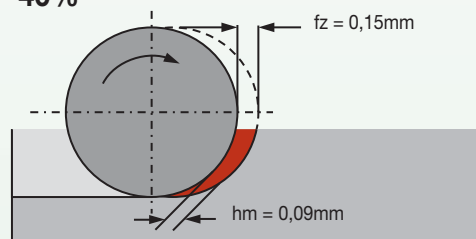

20%

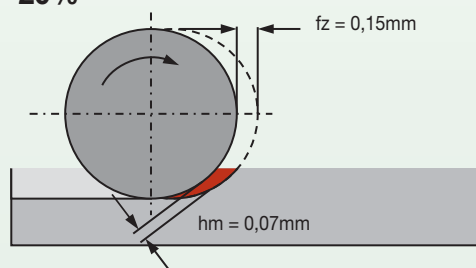

10%

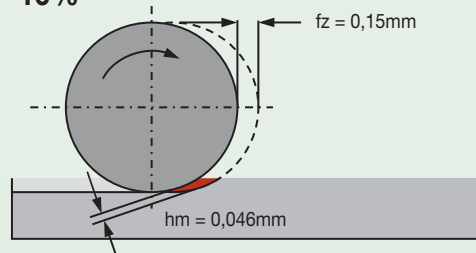

Helix Angle and Chip Thickness

The chip thickness (h) depends on the helix angle of the cutting edge. If the feed fz is constant, the chip thickness gets thinner as helix angle rises. That means with more helix angle, the chip gets thinner — or you can rise feed rate to increase productivity and load to the cutting edge.

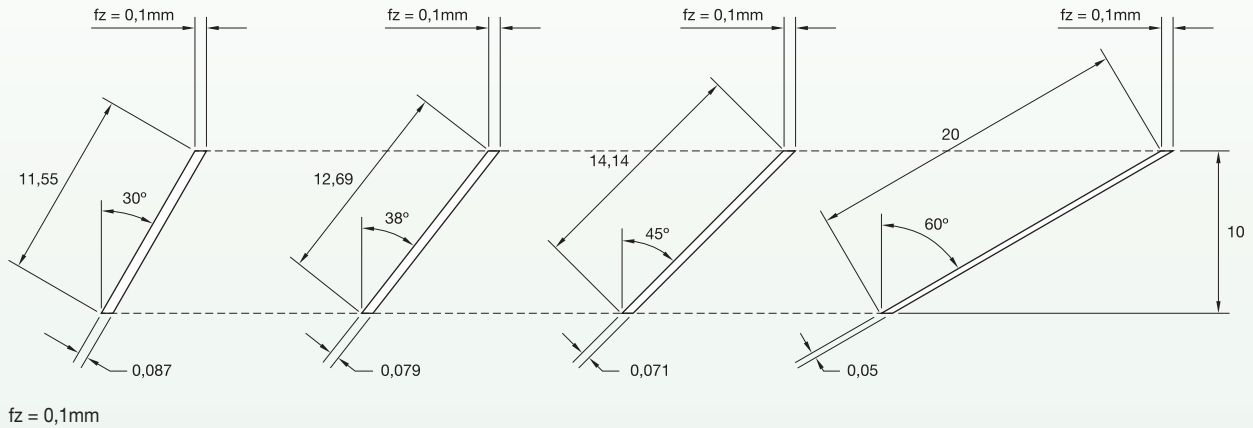

Calculation of Chip Thickness

The chip thickness (h) is not constant, but defines the load of the cutting edge. By reducing the load on the cutting edge, machining at higher speeds is possible through the machining parameters. For easier calculation, use an average chip thickness h_m . When calculating machining data this way cutting data may be compromised because the workpiece is often a different shape.

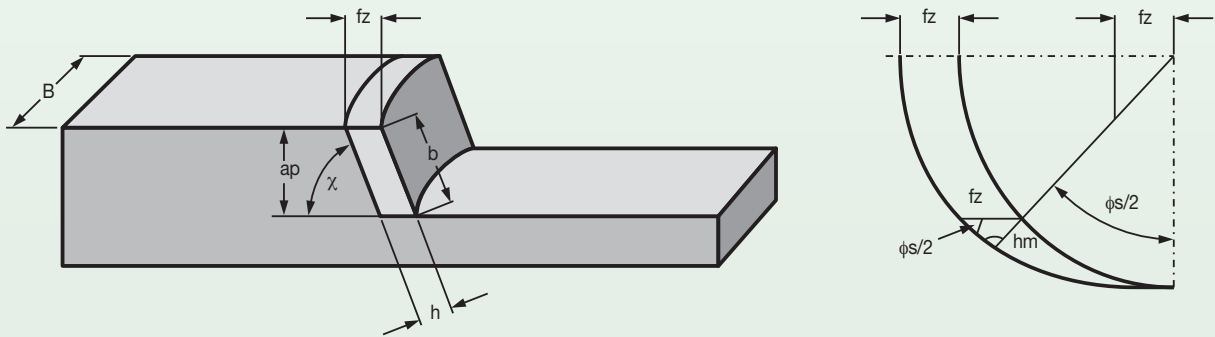

$$h_m = \frac{360^\circ}{\pi \cdot \phi_s} \cdot \frac{a_e}{D} \cdot f_z \cdot \sin \chi$$

- h_m [mm] = average chip thickness
- ϕ_s [°] = engagement angle
- a_e [mm] = width of engagement
- D_1 [mm] = outer diameter tool
- f_z [mm] = feed per tooth
- χ [°] = lead angle
- λ [°] = helix angle *

* Solid End Mills: $\chi = 90^\circ - \lambda$

Trochoidal Milling can be performed with solid or indexable milling tools.

■ Differences between hm and hx

In conventional milling, it makes sense to calculate the load to the cutting edge through hm. With reducing the ae to very low values, you can calculate with the maximum chip thickness hx to make sure that the feed per tooth is set up correctly.

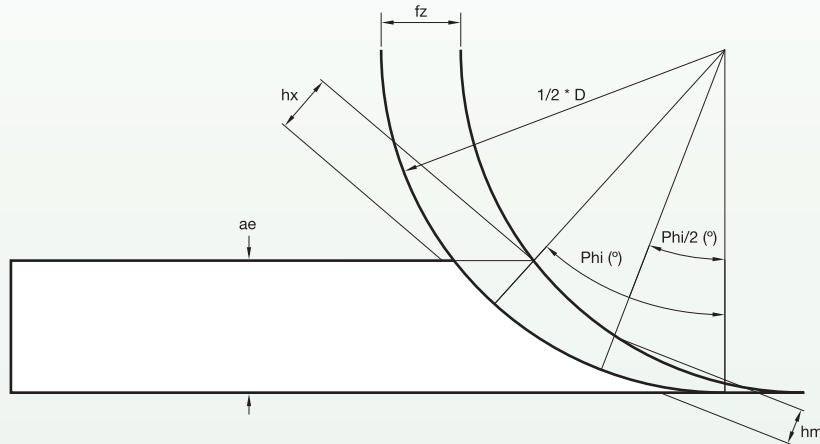

Conventional

$$hm = 360^\circ / \pi \cdot \phi_s \cdot ae / D \cdot fz \cdot \sin x$$

- hm [mm] = average chip thickness
- fs [°] = engagement angle
- ae [mm] = width of engagement
- D1 [mm] = outer diameter tool
- fz [mm] = feed per tooth
- χ [°] = lead angle
- λ [°] = helix angle *

Smart Machining

$$hx = 360^\circ / \pi \cdot \phi_s \cdot 2 \cdot ae / D \cdot fz \cdot \sin x$$

- hx [mm] = maximum chip thickness
- fs [°] = engagement angle
- ae [mm] = width of engagement
- D1 [mm] = outer diameter tool
- fz [mm] = feed per tooth
- χ [°] = lead angle
- λ [°] = helix angle *

* Solid End Mills: $\chi = 90^\circ - \lambda$

Trochoidal Milling can be performed with solid or indexable milling tools.

■ **Cutting Speed**

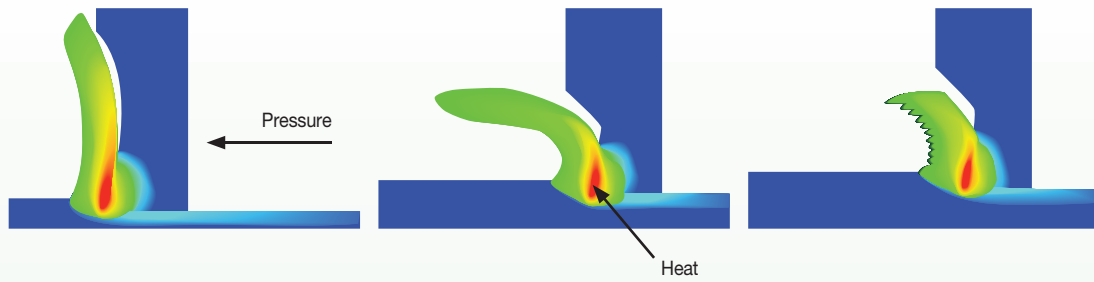

Reduced radial engagement influences the cutting speed, because the heat produced through the cutting process limits the cutting speed.

ae/D	full slot	50% ae	40% ae	30% ae	20% ae	10% ae	5% ae	4% ae
speed factors	0,9	1	1,1	1,2	1,3	1,4	2,5	3
phi [°]	180	90	78,46	66,42	53,13	36,87	25,84	23,07

■ **Static Trochoidal Milling for a Full Slot**

- Use a tool in which $D < b$.
- Program circles in the CNC program (as a cycle).
- After one circle, repeat the same with an offset.
- Optimise by shortening the lane "in the air" to a form like a "D".

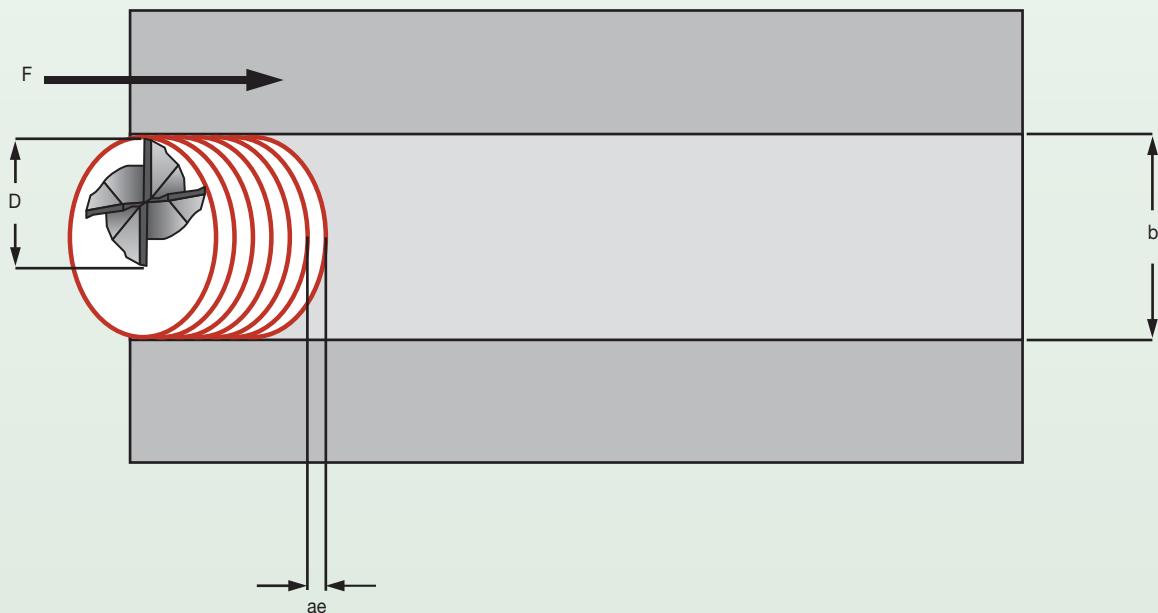

Trochoidal Milling can be performed with solid or indexable milling tools.

■ Dynamic Trochoidal Milling

- Transfer the basic idea control of chip thickness to dynamic processes.
- Dynamic adaption of feed in relation to ae and wrap angle through an intelligent CAM Software.
- Using helix interpolation, D-lanes, and morphing cycles.

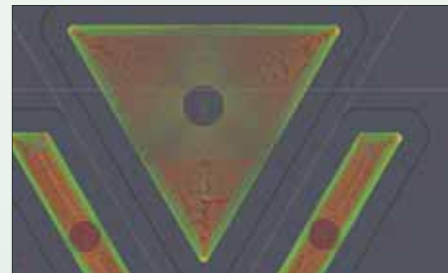
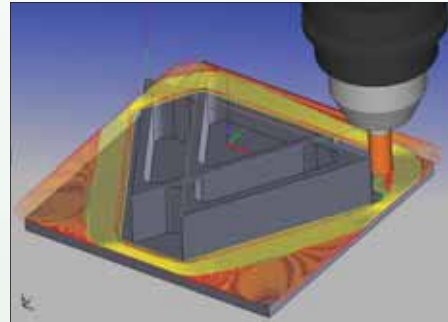
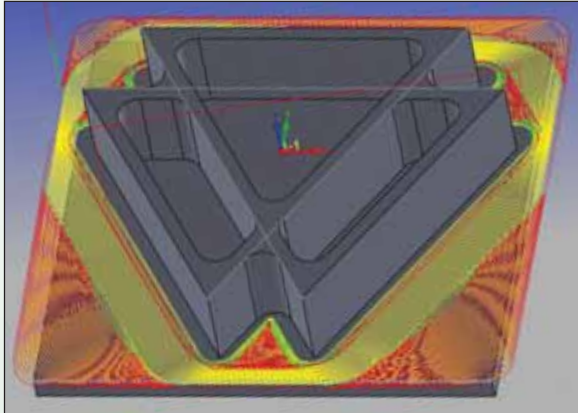

■ Requirments

Static Trochoidal Milling

- Dynamic machine.
- CNC-Programming.
- Modern tool.
- Cutting data for trochoidal machining.

Dynamic Trochoidal Milling

- Dynamic CNC-machine.
- CAD/CAM solutions like iMachining from SolidCAM.
- Modern tool.
- Cutting data for trochoidal machining.

■ Benefits





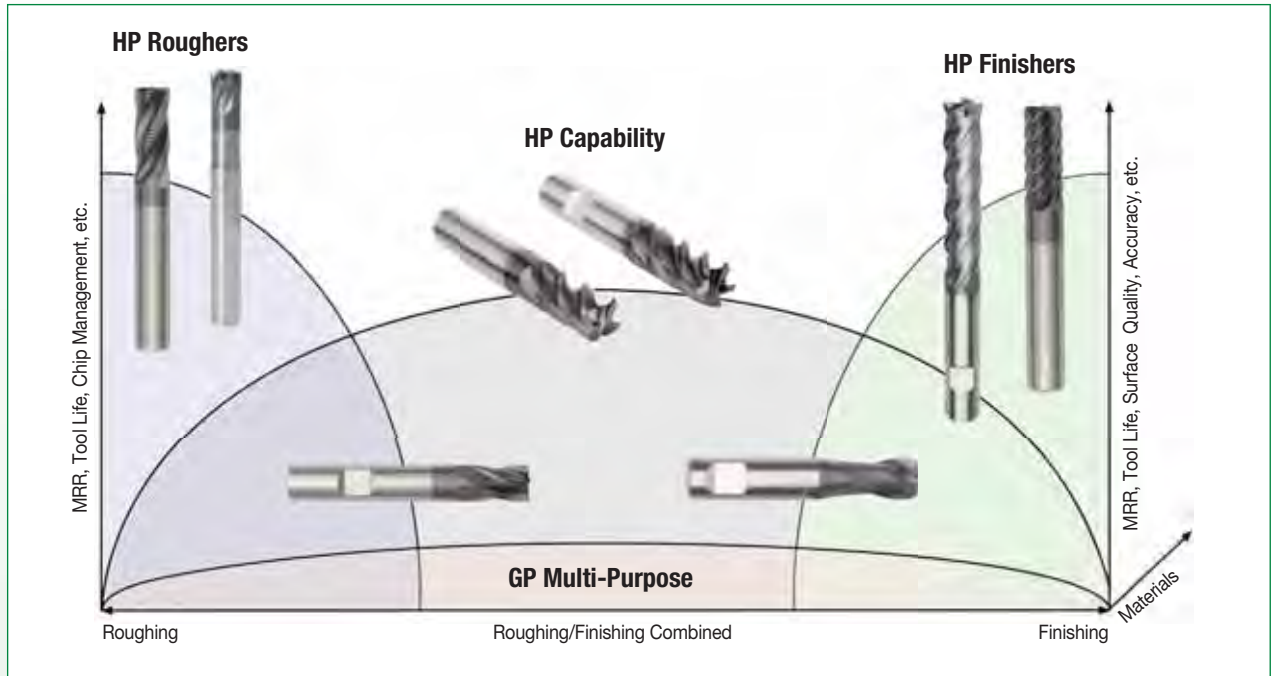



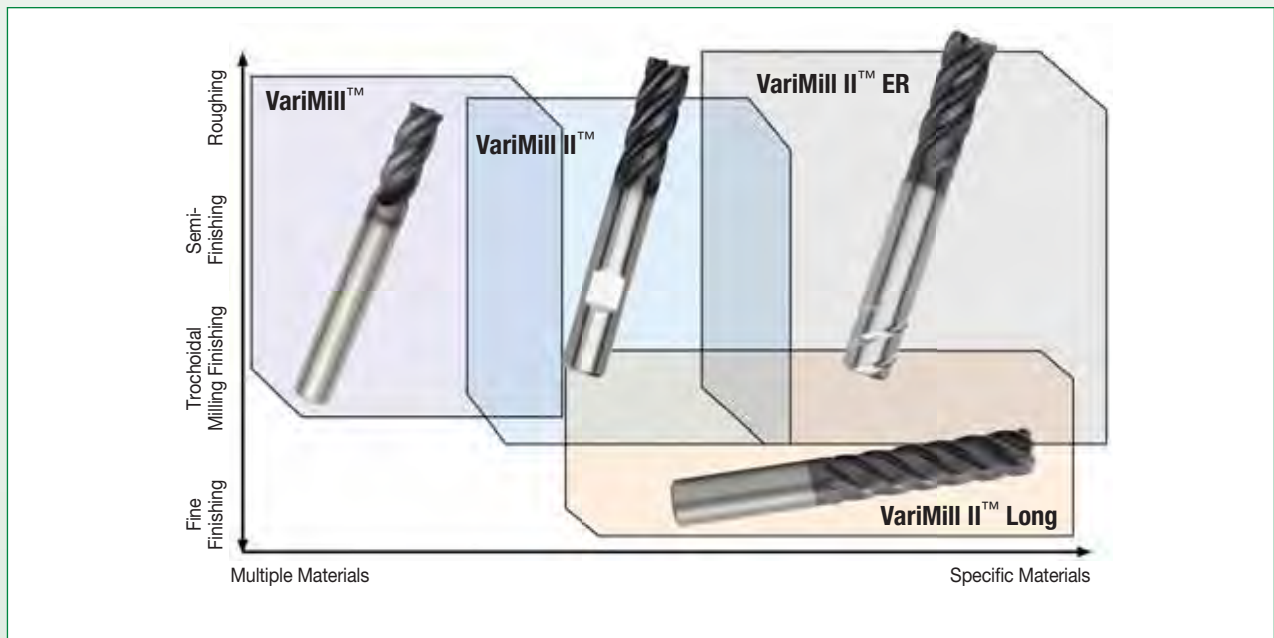

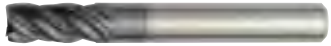





- Constant chip thickness.
- Reduced arc/angle engagement (wrap angle).
- Tremendously reduced load on the cutting edge.
- Reduced temperature during the machining process.
- Higher cutting speed and feed per tooth possible.
- Reduced cycle time and increased tool life.
- Better chip evacuation.
- Better usage of the tool length.
- Less torque and power requirements for the machine.
- Lower risk of spindle damages through torque fluctuation. and reduced torque peaks caused by conventional milling processes.

■ **Tools for Smart Milling**



■ **Tools for Trochoidal Milling**



<ul style="list-style-type: none"> ● First choice ○ Alternate choice ★ Possible with limited tool life and function ★★ Technically possible ★★★ Recommended ✕ Available as standard — Not recommended 											Series	Range of Diameter Ø min–Ø max mm	Number of Flutes	Cutting Centre	Full slotting	Side Milling	Ramping/Helical Interpolation	Trochoidal	High-Feed	
High-Performance Solid Carbide End Mills • VariMill™																				
VariMill I™																				
	4777	4–25	4	Yes	●	●	●	●	—											
	4778	4–25	4	Yes	●	●	●	●	—											
	4717	6–20	4	Yes	—	●	●	●	—											
	4727	12–20	4	Yes	—	●	●	●	—											
	47N7 TIALN	4–20	4	Yes	●	●	●	●	—											
	47N7 ALTiN	4–20	4	Yes	★★	●	●	●	—											
	47N6	6–20	4	Yes	●	●	●	●	—											
	47N0	5–20	4	Yes	★★	●	●	●	—											
VariMill II™																				
	5777	4–25	5	No	★★★	●	●	●	—											
	577C	6–20	5	No	★★★	●	●	●	—											
	57N8	6–25	5	No	★★★	●	●	●	—											
VariMill II™ Long																				
	5717	6–25	5	No	—	●	●	●	—											
VariMill II™ ER																				
	577E	10–25	5	Yes	★	●	●	●	—											
	57NE	10–25	5	Yes	★	★	●	★	—											
High-Performance Solid Carbide End Mills • Hard Materials																				
Vision Plus™ X-Feed™																				
	70N6	6–20	6	No	—	★	●	★★	●											
	70N7/71N7	6–20	6	No	—	★	●	★★	●											
Rougher																				
	49N6	4–25	3–5	Yes	●	●	●	●	—											

VariMill I™ • High-Performance Solid Carbide End Mills

VariMill I are the most universal end mills for use in a wide range of workpiece materials and types of operations. Plunging, slotting, and profiling at highest feed rates are possible. VariMill I is combining roughing and finishing operations into one while designed to provide maximum metal removal rates and achieving supreme surface conditions. A wide range of diameters and corner configurations such as chamfer, radii, and sharp edges are available from stock.



VariMill I

- High-performance universal tools for almost all materials to cut.
- Roughing and finishing with one tool.
- Various length of cut, long reach and necked versions, ball nose, corner chamfer, and corner radius available.
- Use all VariMill I series for trochoidal milling.

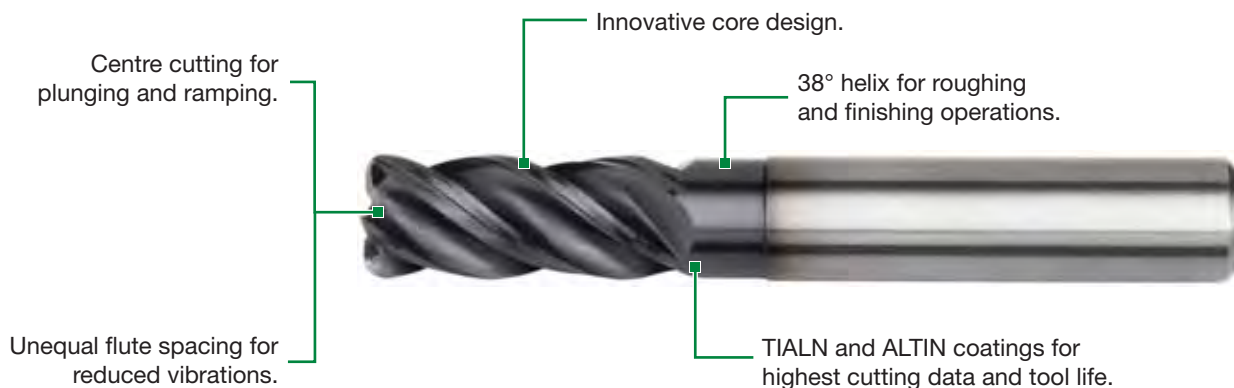

VariMill I™ Series

- Increase your output due to less tool changes and increased metal removal rates.
- No specific tools for roughing and finishing necessary.
- Less passes due to 1 x D slotting capability on almost all types of materials (not recommended for 4717 and 4727).

4777 Series

- High Metal Removal Rates (MRR) and tool life.
- Stainless steels, steels and alloyed steels.
- Cast iron.
- High-temperature alloys and titanium.



4778 ALTIN Series

- Titanium geometry design.
- Corner radii.



4717 Series

- Stainless steel and steel geometry design.
- ~ 3.5 x D length of cut.
- Less passes necessary for long wall machining.



4727 Series

- Stainless steel and steel geometry design.
- ~ 5-6 x D length of cut.
- Less passes necessary for long wall machining.

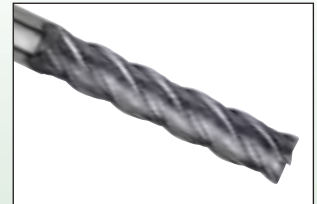

47N7 TIALN Series

- Stainless steel and steel geometry design.
- Radii corner and neck design for cutting depths requiring additional passes.



47N7 ALTIN Series

- Titanium and stainless steel geometry design.
- Radii corner and neck design for depths requiring additional passes.



47N6 Series

- Stainless steel and steel geometry design.
- Benefit from long reach and neck design for deep cavities.



47N0 Series

- Stainless steel and steel geometry design.
- Centre cutting ball nose.



- Unequal flute spacing.
- Centre cutting.
- Single tool for both roughing and finishing operations requiring fewer setups.
- Standard items listed. Additional styles and coatings made to order.

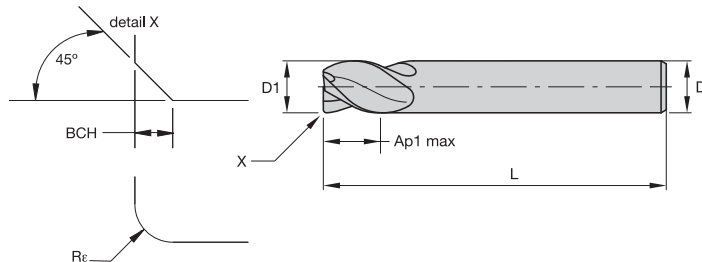
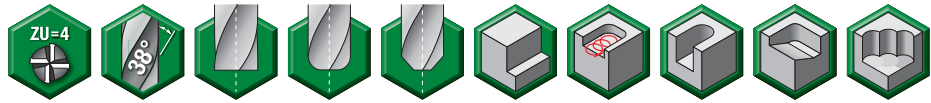

End Mill Tolerances

D1	tolerance e8	D	tolerance h6 + / -
≤ 3	-0,014/-0,028	≤ 3	0/0,006
> 3-6	-0,020/-0,038	> 3-6	0/0,008
> 6-10	-0,025/-0,047	> 6-10	0/0,009
> 10-18	-0,032/-0,059	> 10-18	0/0,011
> 18-30	-0,040/-0,073	> 18-30	0/0,013

	P						M			K			S				H	
	1	2	3	4	5	6	1	2	3	1	2	3	1	2	3	4	1	
TIALN	●	●	●	●	○	○	●	●	●	○	○	○	●	○	○	○	○	●

P – Steels K – Cast Iron S – High-Temp Alloys
M – Stainless Steels N – Non-Ferrous H – Hard Materials

For application data, see page 17.

■ Series 4777 • VariMill I



TIALN-LT	TIALN-LW	D1	D	length of cut Ap1 max	length L	Re	BCH
477704002LT	477704002LW	4,0	6	12,00	55	—	0,40
477704012LT	—	4,0	6	12,00	55	0,20	—
4777040Z2LT	—	4,0	6	12,00	55	—	—
477705002LT	477705002LW	5,0	6	13,00	57	—	0,40
477705012LT	—	5,0	6	13,00	57	0,20	—
4777050Z2LT	—	5,0	6	13,00	57	—	—
477706002LT	477706002LW	6,0	6	13,00	57	—	0,40
477706012LT	—	6,0	6	13,00	57	0,20	—
4777060Z2LT	—	6,0	6	13,00	57	—	—
477707003LT	477707003LW	7,0	8	16,00	63	—	0,40
477707013LT	—	7,0	8	16,00	63	0,20	—
4777070Z3LT	—	7,0	8	16,00	63	—	—
477708003LT	477708003LW	8,0	8	16,00	63	—	0,40
477708013LT	—	8,0	8	16,00	63	0,20	—
4777080Z3LT	—	8,0	8	16,00	63	—	—
477709004LT	477709004LW	9,0	10	19,00	72	—	0,50

(continued)

(Series 4777 • VariMill I – continued)

	P						M			K			S				H
	1	2	3	4	5	6	1	2	3	1	2	3	1	2	3	4	1
TIALN	●	●	●	●	○	○	●	●	●	○	○	○	○	○	○	○	○

P – Steels K – Cast Iron S – High-Temp Alloys
M – Stainless Steels N – Non-Ferrous H – Hard Materials

For application data, see page 17.

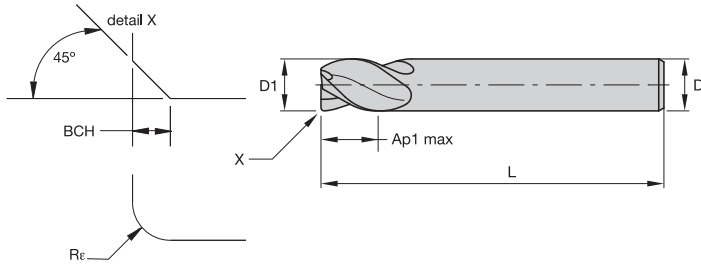

TIALN-LT	TIALN-LW	D1	D	length of cut Ap1 max	length L	Re	BCH
477709014LT	-	9,0	10	19,00	72	0,20	-
4777090Z4LT	-	9,0	10	19,00	72	-	-
477710004LT	477710004LW	10,0	10	22,00	72	-	0,50
477710024LT	-	10,0	10	22,00	72	0,30	-
4777100Z4LT	-	10,0	10	22,00	72	-	-
4777110Z5LT	-	11,0	12	26,00	83	-	-
477712005LT	477712005LW	12,0	12	26,00	83	-	0,50
477712025LT	-	12,0	12	26,00	83	0,30	-
4777120Z5LT	-	12,0	12	26,00	83	-	-
477714014LT	477714014LW	14,0	14	26,00	83	-	0,50
477716006LT	477716006LW	16,0	16	32,00	92	-	0,50
477716026LT	-	16,0	16	32,00	92	0,30	-
4777160Z6LT	-	16,0	16	32,00	92	-	-
477718018LT	477718018LW	18,0	18	32,00	92	-	0,50
477720007LT	477720007LW	20,0	20	38,00	104	-	0,50
477720027LT	-	20,0	20	38,00	104	0,30	-
4777200Z7LT	-	20,0	20	38,00	104	-	-
477725008LT	477725008LW	25,0	25	45,00	121	-	0,50

- Unequal flute spacing.
- Centre cutting.
- Optimised geometry for titanium machining.
- Single tool for both roughing and finishing operations requiring fewer setups.
- Standard items listed. Additional styles and coatings made to order.

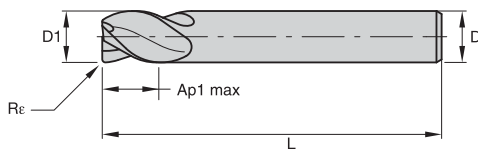
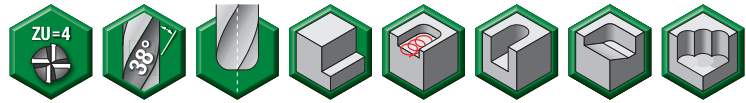

End Mill Tolerances

D1	tolerance e8	D	tolerance h6 + / -
≤ 3	-0,014 / -0,028	≤ 3	0/0,006
> 3-6	-0,020 / -0,038	> 3-6	0/0,008
> 6-10	-0,025 / -0,047	> 6-10	0/0,009
> 10-18	-0,032 / -0,059	> 10-18	0/0,011
> 18-30	-0,040 / -0,073	> 18-30	0/0,013

	P						M			K			S				H
	1	2	3	4	5	6	1	2	3	1	2	3	1	2	3	4	1
ALTIN	●	●	○	○	●	●	●	●	○	○	○	○	○	●	●	●	●

P – Steels K – Cast Iron S – High-Temp Alloys
M – Stainless Steels N – Non-Ferrous H – Hard Materials

For application data, see page 18.

■ Series 4778 • VariMill I



ALTIN-MT	ALTIN-MW	D1	D	length of cut Ap1 max	length L	Re
477804002MT	477804002MW	4,0	6	12,00	55	0,20
477805002MT	477805002MW	5,0	6	13,00	57	0,20
477806002MT	477806002MW	6,0	6	13,00	57	0,20
477807003MT	477807003MW	7,0	8	16,00	63	0,20
477808003MT	477808003MW	8,0	8	16,00	63	0,20
477809004MT	477809004MW	9,0	10	19,00	72	0,30
477810004MT	477810004MW	10,0	10	22,00	72	0,30
477812005MT	477812005MW	12,0	12	26,00	83	0,30
477814014MT	477814014MW	14,0	14	26,00	83	0,30
477816006MT	477816006MW	16,0	16	32,00	92	0,30
477818018MT	477818018MW	18,0	18	32,00	92	0,30
477820007MT	477820007MW	20,0	20	38,00	104	0,30
477825008MT	477825008MW	25,0	25	45,00	121	0,30

Series 4777 • VariMill™

Material Group							Recommended feed per tooth (fz=mm/th) for side milling (A). For slotting (B), reduce fz by 20%.										
	Side Milling (A) and Slotting (B)		TIALN														
	A		B		Cutting Speed – vc m/min			D1 – Diameter									
	ap	ae	ap	min		max	mm	4,0	6,0	8,0	10,0	12,0	16,0	20,0	25,0		
P	1	1,5 x D	0,5 x D	1 x D	150	–	200	fz	0,028	0,044	0,060	0,072	0,083	0,101	0,114	0,124	
	2	1,5 x D	0,5 x D	1 x D	140	–	190	fz	0,028	0,044	0,060	0,072	0,083	0,101	0,114	0,124	
	3	1,5 x D	0,5 x D	1 x D	120	–	160	fz	0,023	0,036	0,050	0,061	0,070	0,087	0,101	0,114	
	4	1,5 x D	0,5 x D	0,75 x D	90	–	150	fz	0,021	0,033	0,045	0,054	0,062	0,077	0,088	0,098	
	5	1,5 x D	0,5 x D	1 x D	60	–	100	fz	0,019	0,029	0,040	0,048	0,056	0,070	0,081	0,091	
	6	1,5 x D	0,5 x D	0,75 x D	50	–	75	fz	0,016	0,025	0,034	0,040	0,047	0,057	0,065	0,071	
M	1	1,5 x D	0,5 x D	1 x D	90	–	115	fz	0,023	0,036	0,050	0,061	0,070	0,087	0,101	0,114	
	2	1,5 x D	0,5 x D	1 x D	60	–	80	fz	0,019	0,029	0,040	0,048	0,056	0,070	0,081	0,091	
	3	1,5 x D	0,5 x D	1 x D	60	–	70	fz	0,016	0,025	0,034	0,040	0,047	0,057	0,065	0,071	
K	1	1,5 x D	0,5 x D	1 x D	120	–	150	fz	0,028	0,044	0,060	0,072	0,083	0,101	0,114	0,124	
	2	1,5 x D	0,5 x D	1 x D	110	–	130	fz	0,023	0,036	0,050	0,061	0,070	0,087	0,101	0,114	
	3	1,5 x D	0,5 x D	1 x D	100	–	130	fz	0,019	0,029	0,040	0,048	0,056	0,070	0,081	0,091	
S	1	1,5 x D	0,3 x D	0,3 x D	50	–	90	fz	0,023	0,036	0,050	0,061	0,070	0,087	0,101	0,114	
	2	1,5 x D	0,3 x D	0,3 x D	25	–	40	fz	0,013	0,019	0,026	0,032	0,037	0,046	0,054	0,061	
	3	1,5 x D	0,5 x D	1 x D	60	–	80	fz	0,019	0,029	0,040	0,048	0,056	0,070	0,081	0,091	
	4	1,5 x D	0,5 x D	1 x D	50	–	60	fz	0,016	0,026	0,037	0,045	0,052	0,064	0,074	0,084	
H	1	1,5 x D	0,5 x D	0,75 x D	80	–	140	fz	0,021	0,033	0,045	0,054	0,062	0,077	0,088	0,098	

NOTE: Lower value of cutting speed is used for high-stock removal applications or for higher hardness (machinability) within group.

Higher value of cutting speed is used for finishing applications or for lower hardness (machinability) within group.

Above parameters are based on ideal conditions. For smaller taper machining centres, please adjust parameters accordingly on >12mm diameter.

■ Series 4778 • VariMill™

Material Group								Recommended feed per tooth (fz=mm/th) for side milling (A). For slotting (B), reduce fz by 20%.								
	Side Milling (A) and Slotting (B)		ALTIN													
	A		B	Cutting Speed – vc m/min			D1 – Diameter									
	ap	ae	ap	min		max	mm	4,0	6,0	8,0	10,0	12,0	16,0	20,0	25,0	
P	1	1,5 x D	0,5 x D	1 x D	150	–	200	fz	0,028	0,044	0,060	0,072	0,083	0,101	0,114	0,124
	2	1,5 x D	0,5 x D	1 x D	140	–	190	fz	0,028	0,044	0,060	0,072	0,083	0,101	0,114	0,124
	3	1,5 x D	0,5 x D	1 x D	120	–	160	fz	0,023	0,036	0,050	0,061	0,070	0,087	0,101	0,114
	4	1,5 x D	0,5 x D	0,75 x D	90	–	150	fz	0,021	0,033	0,045	0,054	0,062	0,077	0,088	0,098
	5	1,5 x D	0,5 x D	1 x D	60	–	100	fz	0,019	0,029	0,040	0,048	0,056	0,070	0,081	0,091
	6	1,5 x D	0,5 x D	0,75 x D	50	–	75	fz	0,016	0,025	0,034	0,040	0,047	0,057	0,065	0,071
M	1	1,5 x D	0,5 x D	1 x D	90	–	115	fz	0,023	0,036	0,050	0,061	0,070	0,087	0,101	0,114
	2	1,5 x D	0,5 x D	1 x D	60	–	80	fz	0,019	0,029	0,040	0,048	0,056	0,070	0,081	0,091
	3	1,5 x D	0,5 x D	1 x D	60	–	70	fz	0,016	0,025	0,034	0,040	0,047	0,057	0,065	0,071
K	1	1,5 x D	0,5 x D	1 x D	120	–	150	fz	0,028	0,044	0,060	0,072	0,083	0,101	0,114	0,124
	2	1,5 x D	0,5 x D	1 x D	110	–	130	fz	0,023	0,036	0,050	0,061	0,070	0,087	0,101	0,114
	3	1,5 x D	0,5 x D	1 x D	100	–	130	fz	0,019	0,029	0,040	0,048	0,056	0,070	0,081	0,091
S	1	1,5 x D	0,3 x D	0,3 x D	50	–	90	fz	0,023	0,036	0,050	0,061	0,070	0,087	0,101	0,114
	2	1,5 x D	0,3 x D	0,3 x D	25	–	40	fz	0,013	0,019	0,026	0,032	0,037	0,046	0,054	0,061
	3	1,5 x D	0,5 x D	1 x D	60	–	80	fz	0,019	0,029	0,040	0,048	0,056	0,070	0,081	0,091
	4	1,5 x D	0,5 x D	1 x D	50	–	60	fz	0,016	0,026	0,037	0,045	0,052	0,064	0,074	0,084
H	1	1,5 x D	0,5 x D	0,75 x D	80	–	140	fz	0,021	0,033	0,045	0,054	0,062	0,077	0,088	0,098

NOTE: Lower value of cutting speed is used for high-stock removal applications or for higher hardness (machinability) within group.
Higher value of cutting speed is used for finishing applications or for lower hardness (machinability) within group.
Above parameters are based on ideal conditions. For smaller taper machining centres, please adjust parameters accordingly on >12mm diameter.

■ Series 4777 4778 • Trochoidal Milling/Peel Milling

ae/D	50% ae	40% ae	30% ae	20% ae	10% ae	5% ae	4% ae	2% ae
Speed factors vc	1	1.1	1.2	1.3	1.4	2.5	3	4
Feed factors fz	1	1	1.1	1.4	2	2.5	3	4.4
phi [°]	90	78.46	66.42	53.13	36.87	25.84	23.07	16.26

Material Group	Cutting Speed – vc m/min	D	4	6	8	10	12	16	20	25		
P	1	vc max [m/min]	vf	16488	17273	17666	16959	16292	14869	13426	11683	mm/min
		600	n	47746	31831	23873	19099	15915	11937	9549	7639	min ⁻¹
	2	vc max [m/min]	vf	15663	16409	16782	16111	15477	14125	12755	11099	mm/min
		570	n	45359	30239	22680	18144	15120	11340	9072	7257	min ⁻¹
	3	vc max [m/min]	vf	11668	12224	12502	12002	11529	10522	9501	8268	mm/min
		480	n	38197	25465	19099	15279	12732	9549	7639	6112	min ⁻¹
	4	vc max [m/min]	vf	9512	9965	10192	9784	9399	8578	7746	6740	mm/min
		450	n	35810	23873	17905	14324	11937	8952	7162	5730	min ⁻¹
	5	vc max [m/min]	vf	5707	5979	6115	5870	5639	5147	4647	4044	mm/min
		300	n	23873	15915	11937	9549	7958	5968	4775	3820	min ⁻¹
	6	vc max [m/min]	vf	3567	3737	3822	3669	3525	3217	2905	2528	mm/min
		225	n	17905	11937	8952	7162	5968	4476	3581	2865	min ⁻¹
M	1	vc max [m/min]	vf	8387	8786	8986	8626	8287	7563	6829	5943	mm/min
		345	n	27454	18303	13727	10982	9151	6864	5491	4393	min ⁻¹
	2	vc max [m/min]	vf	4566	4783	4892	4696	4512	4117	3718	3235	mm/min
		240	n	19099	12732	9549	7639	6366	4775	3820	3056	min ⁻¹
	3	vc max [m/min]	vf	3329	3488	3567	3424	3290	3002	2711	2359	mm/min
		210	n	16711	11141	8356	6685	5570	4178	3342	2674	min ⁻¹
K	1	vc max [m/min]	vf	12366	12955	13249	12719	12219	11151	10069	8762	mm/min
		450	n	35810	23873	17905	14324	11937	8952	7162	5730	min ⁻¹
	2	vc max [m/min]	vf	9481	9932	10158	9751	9368	8549	7720	6718	mm/min
		390	n	31035	20690	15518	12414	10345	7759	6207	4966	min ⁻¹
	3	vc max [m/min]	vf	7420	7773	7949	7632	7331	6691	6042	5257	mm/min
		390	n	31035	20690	15518	12414	10345	7759	6207	4966	min ⁻¹
S	1	vc max [m/min]	vf	6563	6876	7032	6751	6485	5919	5345	4651	mm/min
		270	n	21486	14324	10743	8594	7162	5371	4297	3438	min ⁻¹
	2	vc max [m/min]	vf	1522	1594	1631	1565	1504	1372	1239	1078	mm/min
		120	n	9549	6366	4775	3820	3183	2387	1910	1528	min ⁻¹
	3	vc max [m/min]	vf	4566	4783	4892	4696	4512	4117	3718	3235	mm/min
		240	n	19099	12732	9549	7639	6366	4775	3820	3056	min ⁻¹
	4	vc max [m/min]	vf	3044	3189	3261	3131	3008	2745	2479	2157	mm/min
		180	n	14324	9549	7162	5730	4775	3581	2865	2292	min ⁻¹
H	1	vc max [m/min]	vf	8878	9301	9512	9132	8772	8006	7229	6291	mm/min
		420	n	33423	22282	16711	13369	11141	8356	6685	5348	min ⁻¹

NOTE: For all other combinations of width and depth of cut, feed and speed must be adapted.
Cutting data, which are shown in this catalogue, are applicable under optimum conditions and chip evacuation.

Recommended ae: 0,04 x D, phi-23°, ap = ap max

Speed and feed: 4% ae

- Unequal flute spacing.
- Centre cutting.
- Standard items listed. Additional styles and coatings made to order.

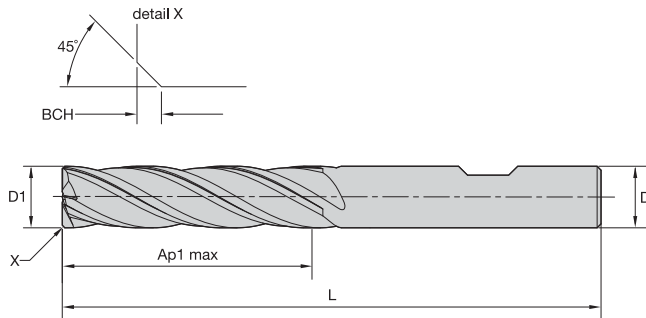
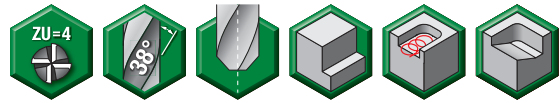

End Mill Tolerances

D1	tolerance e8	D	tolerance h6 + / -
≤ 3	-0,014/-0,028	≤ 3	0/0,006
> 3-6	-0,020/-0,038	> 3-6	0/0,008
> 6-10	-0,025/-0,047	> 6-10	0/0,009
> 10-18	-0,032/-0,059	> 10-18	0/0,011
> 18-30	-0,040/-0,073	> 18-30	0/0,013

TIALN	P						M			K			S				H
	1	2	3	4	5	6	1	2	3	1	2	3	1	2	3	4	1
TIALN	●	●	●	●	●	●	●	●	●	○	○	○	●	●	●	●	●

P – Steels K – Cast Iron S – High-Temp Alloys
M – Stainless Steels N – Non-Ferrous H – Hard Materials

For application data, see page 22.

■ Series 4717 • VariMill I™ • Extended Length of Cut



TIALN-LW	D1	D	length of cut Ap1 max	length L	BCH
471706002LW	6,0	6	32,00	76	0,40
471708003LW	8,0	8	32,00	87	0,40
471710004LW	10,0	10	38,00	89	0,50
471712005LW	12,0	12	51,00	100	0,50
471716006LW	16,0	16	57,00	125	0,50
471720007LW	20,0	20	57,00	125	0,50

- Unequal flute spacing.
- Centre cutting.
- Standard items listed. Additional styles and coatings made to order.

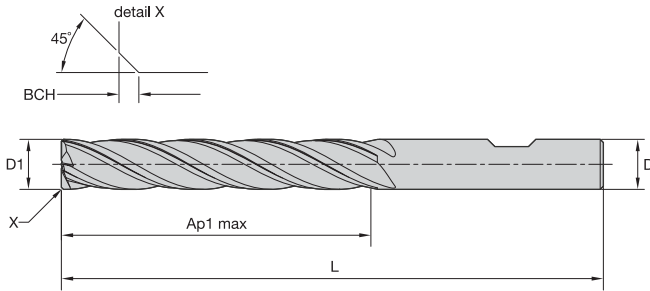
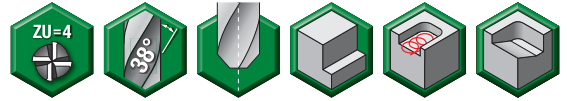

End Mill Tolerances

D1	tolerance e8	D	tolerance h6 + / -
≤ 3	-0,014/-0,028	≤ 3	0/0,006
> 3-6	-0,020/-0,038	> 3-6	0/0,008
> 6-10	-0,025/-0,047	> 6-10	0/0,009
> 10-18	-0,032/-0,059	> 10-18	0/0,011
> 18-30	-0,040/-0,073	> 18-30	0/0,013

	P						M			K			S				H
	1	2	3	4	5	6	1	2	3	1	2	3	1	2	3	4	1
TIALN	●	●	●	●	●	●	●	●	●	○	○	○	●	●	●	●	●

P – Steels K – Cast Iron S – High-Temp Alloys
M – Stainless Steels N – Non-Ferrous H – Hard Materials

For application data, see page 22.

■ **Series 4727 • VariMill I • Extended Length of Cut**



TIALN-LW	D1	D	length of cut Ap1 max	length L	BCH
472712005LW	12,0	12	76,00	125	0,50
472716006LW	16,0	16	76,00	150	0,50
472720007LW	20,0	20	102,00	175	0,50

■ Series 4717 • VariMill I

Material Group																			
				Finish						Rough				Recommended feed per tooth (fz=mm/th) for side milling (A).					
		A		TIALN		A		TIALN		D1 – Diameter									
				Cutting Speed – vc m/min				Cutting Speed – vc m/min		mm	6,0	8,0	10,0	12,0	16,0	20,0			
ap	ae	min	max	ap	ae	min	max	mm	6,0	8,0	10,0	12,0	16,0	20,0					
P	1	Ap1 max	0,05 x D*	300	–	400	Ap1 max	0,2 x D	150	–	200	fz	0,044	0,060	0,072	0,083	0,092	0,114	
	2	Ap1 max	0,05 x D*	280	–	380	Ap1 max	0,2 x D	140	–	190	fz	0,044	0,060	0,072	0,083	0,092	0,114	
	3	Ap1 max	0,05 x D*	240	–	320	Ap1 max	0,2 x D	120	–	160	fz	0,036	0,050	0,061	0,070	0,079	0,101	
	4	Ap1 max	0,05 x D*	180	–	300	Ap1 max	0,2 x D	90	–	150	fz	0,033	0,045	0,054	0,062	0,070	0,088	
	5	Ap1 max	0,05 x D*	120	–	200	Ap1 max	0,2 x D	60	–	100	fz	0,029	0,040	0,048	0,056	0,063	0,081	
	6	Ap1 max	0,05 x D*	100	–	150	Ap1 max	0,2 x D	50	–	75	fz	0,025	0,034	0,040	0,047	0,052	0,065	
M	1	Ap1 max	0,05 x D*	180	–	230	Ap1 max	0,2 x D	90	–	115	fz	0,036	0,050	0,061	0,070	0,079	0,101	
	2	Ap1 max	0,05 x D*	120	–	160	Ap1 max	0,2 x D	60	–	80	fz	0,029	0,040	0,048	0,056	0,063	0,081	
	3	Ap1 max	0,05 x D*	120	–	140	Ap1 max	0,2 x D	60	–	70	fz	0,025	0,034	0,040	0,047	0,052	0,065	
K	1	Ap1 max	0,05 x D*	240	–	300	Ap1 max	0,2 x D	120	–	150	fz	0,044	0,060	0,072	0,083	0,092	0,114	
	2	Ap1 max	0,05 x D*	220	–	260	Ap1 max	0,2 x D	110	–	130	fz	0,036	0,050	0,061	0,070	0,079	0,101	
	3	Ap1 max	0,05 x D*	200	–	260	Ap1 max	0,2 x D	100	–	130	fz	0,029	0,040	0,048	0,056	0,063	0,081	
S	1	Ap1 max	0,05 x D*	100	–	180	Ap1 max	0,2 x D	50	–	90	fz	0,036	0,050	0,061	0,070	0,079	0,101	
	2	Ap1 max	0,05 x D*	50	–	80	Ap1 max	0,2 x D	25	–	40	fz	0,036	0,050	0,061	0,070	0,079	0,101	
	3	Ap1 max	0,05 x D*	120	–	160	Ap1 max	0,2 x D	60	–	80	fz	0,019	0,026	0,032	0,037	0,042	0,054	
	4	Ap1 max	0,05 x D*	100	–	120	Ap1 max	0,2 x D	50	–	60	fz	0,026	0,037	0,045	0,052	0,058	0,074	
H	1	Ap1 max	0,05 x D*	160	–	280	Ap1 max	0,2 x D	80	–	140	fz	0,033	0,045	0,054	0,062	0,070	0,088	

■ Series 4727 • VariMill I

Material Group															
				Finish						Rough				Recommended feed per tooth (fz=mm/th) for side milling (A).	
		A		TIALN		A		TIALN		mm		D1 – Diameter			
				Cutting Speed – vc m/min				Cutting Speed – vc m/min		12,0	16,0	20,0			
ap	ae	min	max	ap	ae	min	max	mm	12,0	16,0	20,0				
P	1	Ap1 max	0,05 x D*	300	–	400	Ap1 max	0,2 x D	150	–	200	fz	0,083	0,101	0,114
	2	Ap1 max	0,05 x D*	280	–	380	Ap1 max	0,2 x D	140	–	190	fz	0,083	0,101	0,114
	3	Ap1 max	0,05 x D*	240	–	320	Ap1 max	0,2 x D	120	–	160	fz	0,070	0,087	0,101
	4	Ap1 max	0,05 x D*	180	–	300	Ap1 max	0,2 x D	90	–	150	fz	0,062	0,077	0,088
	5	Ap1 max	0,05 x D*	120	–	200	Ap1 max	0,2 x D	60	–	100	fz	0,056	0,070	0,081
	6	Ap1 max	0,05 x D*	100	–	150	Ap1 max	0,2 x D	50	–	75	fz	0,047	0,057	0,065
M	1	Ap1 max	0,05 x D*	180	–	230	Ap1 max	0,2 x D	90	–	115	fz	0,070	0,087	0,101
	2	Ap1 max	0,05 x D*	120	–	160	Ap1 max	0,2 x D	60	–	80	fz	0,056	0,070	0,081
	3	Ap1 max	0,05 x D*	120	–	140	Ap1 max	0,2 x D	60	–	70	fz	0,047	0,057	0,065
K	1	Ap1 max	0,05 x D*	240	–	300	Ap1 max	0,2 x D	120	–	150	fz	0,083	0,101	0,114
	2	Ap1 max	0,05 x D*	220	–	260	Ap1 max	0,2 x D	110	–	130	fz	0,070	0,087	0,101
	3	Ap1 max	0,05 x D*	200	–	260	Ap1 max	0,2 x D	100	–	130	fz	0,056	0,070	0,081
S	1	Ap1 max	0,05 x D*	100	–	180	Ap1 max	0,2 x D	50	–	90	fz	0,070	0,087	0,101
	2	Ap1 max	0,05 x D*	50	–	80	Ap1 max	0,2 x D	25	–	40	fz	0,070	0,087	0,101
	3	Ap1 max	0,05 x D*	120	–	160	Ap1 max	0,2 x D	60	–	80	fz	0,037	0,046	0,054
	4	Ap1 max	0,05 x D*	100	–	120	Ap1 max	0,2 x D	50	–	60	fz	0,052	0,064	0,074
H	1	Ap1 max	0,05 x D*	160	–	280	Ap1 max	0,2 x D	80	–	140	fz	0,062	0,077	0,088

*For cutting data above, use ae ≤0,8mm.

NOTE: Lower value of cutting speed is used for high stock removal applications or for higher hardness (machinability) within group.

Higher value of cutting speed is used for finishing applications or for lower hardness (machinability) within group.

Above parameters are based on ideal conditions. For smaller taper machining centres, please adjust parameters accordingly on >12mm diameters.

■ Series 4717 4727 • Trochoidal Milling/Peel Milling

ae/D	5% ae	4% ae	2% ae
Speed factors v_c	2.5	3	4
Feed factors f_z	2.5	3	4.4
ϕ [°]	25.84	23.07	16.26

Material Group	Cutting Speed – v_c [m/min]	D	4	6	8	10	12	16	20	25		
P	1	v_c max [m/min]	vf	14747	15449	15801	15169	14572	13299	12008	10449	mm/min
		600	n	47746	31831	23873	19099	15915	11937	9549	7639	min ⁻¹
	2	v_c max [m/min]	vf	14010	14677	15011	14410	13843	12634	11408	9927	mm/min
		570	n	45359	30239	22680	18144	15120	11340	9072	7257	min ⁻¹
	3	v_c max [m/min]	vf	10436	10933	11182	10735	10312	9411	8498	7395	mm/min
		480	n	38197	25465	19099	15279	12732	9549	7639	6112	min ⁻¹
	4	v_c max [m/min]	vf	8508	8913	9116	8751	8407	7672	6928	6029	mm/min
		450	n	35810	23873	17905	14324	11937	8952	7162	5730	min ⁻¹
	5	v_c max [m/min]	vf	5105	5348	5469	5251	5044	4603	4157	3617	mm/min
		300	n	23873	15915	11937	9549	7958	5968	4775	3820	min ⁻¹
	6	v_c max [m/min]	vf	3190	3342	3418	3282	3153	2877	2598	2261	mm/min
		225	n	17905	11937	8952	7162	5968	4476	3581	2865	min ⁻¹
M	1	v_c max [m/min]	vf	7501	7858	8037	7716	7412	6764	6108	5315	mm/min
		345	n	27454	18303	13727	10982	9151	6864	5491	4393	min ⁻¹
	2	v_c max [m/min]	vf	4084	4278	4376	4201	4035	3683	3325	2894	mm/min
		240	n	19099	12732	9549	7639	6366	4775	3820	3056	min ⁻¹
	3	v_c max [m/min]	vf	2978	3120	3190	3063	2942	2685	2425	2110	mm/min
		210	n	16711	11141	8356	6685	5570	4178	3342	2674	min ⁻¹
K	1	v_c max [m/min]	vf	11060	11587	11850	11376	10929	9974	9006	7837	mm/min
		450	n	35810	23873	17905	14324	11937	8952	7162	5730	min ⁻¹
	2	v_c max [m/min]	vf	8480	8883	9085	8722	8379	7647	6905	6008	mm/min
		390	n	31035	20690	15518	12414	10345	7759	6207	4966	min ⁻¹
	3	v_c max [m/min]	vf	6636	6952	7110	6826	6557	5984	5404	4702	mm/min
		390	n	31035	20690	15518	12414	10345	7759	6207	4966	min ⁻¹
S	1	v_c max [m/min]	vf	5871	6150	6290	6038	5801	5294	4780	4160	mm/min
		270	n	21486	14324	10743	8594	7162	5371	4297	3438	min ⁻¹
	2	v_c max [m/min]	vf	1361	1426	1459	1400	1345	1228	1108	965	mm/min
		120	n	9549	6366	4775	3820	3183	2387	1910	1528	min ⁻¹
	3	v_c max [m/min]	vf	4084	4278	4376	4201	4035	3683	3325	2894	mm/min
		240	n	19099	12732	9549	7639	6366	4775	3820	3056	min ⁻¹
	4	v_c max [m/min]	vf	2723	2852	2917	2800	2690	2455	2217	1929	mm/min
		180	n	14324	9549	7162	5730	4775	3581	2865	2292	min ⁻¹
H	1	v_c max [m/min]	vf	7941	8319	8508	8168	7846	7161	6466	5627	mm/min
		420	n	33423	22282	16711	13369	11141	8356	6685	5348	min ⁻¹

NOTE: For all other combinations of width and depth of cut, feed and speed must be adapted.
Cutting data, which are shown in this catalogue, are applicable under optimum conditions and chip evacuation.

Recommended ae: 0,05 x D, ϕ ~28,8°, a_p = a_p max

Speed and feed: 5% ae

- Unequal flute spacing.
- Centre cutting.
- Single tool for both roughing and finishing operations requiring fewer setups.
- Standard items listed. Additional styles and coatings made to order.

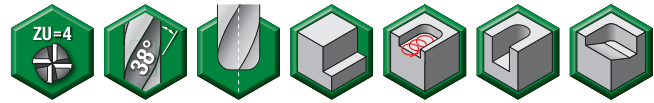

End Mill Tolerances

D1	tolerance e8	D	tolerance h6 +/-
≤ 3	-0,014/-0,028	≤ 3	0/0,006
> 3-6	-0,020/-0,038	> 3-6	0/0,008
> 6-10	-0,025/-0,047	> 6-10	0/0,009
> 10-18	-0,032/-0,059	> 10-18	0/0,011
> 18-30	-0,040/-0,073	> 18-30	0/0,013

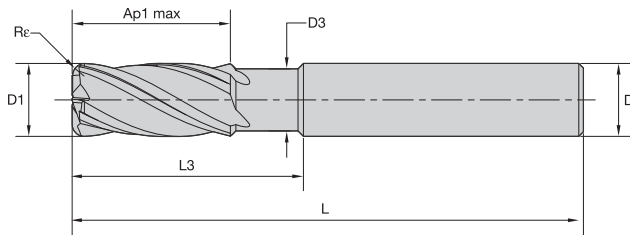

■ Series 47N7 • VariMill I • With Neck



	P						M			K			S				H
	1	2	3	4	5	6	1	2	3	1	2	3	1	2	3	4	1
TIALN	●	●	●	●	○	○	●	●	●	○	○	○	●	○	○	○	●
ALTiN	●	●	●	●	●	●	●	●	●	○	○	○	●	●	●	●	●

P – Steels K – Cast Iron S – High-Temp Alloys
M – Stainless Steels N – Non-Ferrous H – Hard Materials

For application data, see page 25.

TIALN-LT	ALTiN-MT	D1	D	length of cut Ap1 max	L3	length L	Re	D3
47N704002LT	—	4,0	6	12,00	16,00	55	0,40	3,60
47N704012LT	47N704012MT	4,0	6	12,00	16,00	55	0,50	3,60
47N704022LT	—	4,0	6	12,00	16,00	55	1,00	3,60
47N705002LT	—	5,0	6	13,00	18,00	57	0,50	4,60
47N705012LT	47N705012MT	5,0	6	13,00	18,00	57	1,00	4,60
47N706002LT	47N706002MT	6,0	6	13,00	21,00	57	0,50	5,50
47N706012LT	47N706012MT	6,0	6	13,00	21,00	57	1,00	5,50
47N706022LT	—	6,0	6	13,00	21,00	57	1,50	5,50
47N708003LT	47N708003MT	8,0	8	16,00	27,00	63	0,50	7,50
47N708013LT	47N708013MT	8,0	8	16,00	27,00	63	1,00	7,50
47N708023LT	—	8,0	8	16,00	27,00	63	1,50	7,50
47N708033LT	—	8,0	8	16,00	27,00	63	2,00	7,50
47N710004LT	47N710004MT	10,0	10	22,00	32,00	72	0,50	9,50
47N710014LT	47N710014MT	10,0	10	22,00	32,00	72	1,00	9,50
47N710024LT	—	10,0	10	22,00	32,00	72	1,50	9,50
47N710034LT	47N710034MT	10,0	10	22,00	32,00	72	2,00	9,50
47N712005LT	47N712005MT	12,0	12	26,00	38,00	83	0,50	11,50
47N712015LT	47N712015MT	12,0	12	26,00	38,00	83	1,00	11,50
47N712025LT	—	12,0	12	26,00	38,00	83	1,50	11,50
47N712035LT	47N712035MT	12,0	12	26,00	38,00	83	2,00	11,50
47N712045LT	47N712045MT	12,0	12	26,00	38,00	83	4,00	11,50
47N716006LT	47N716006MT	16,0	16	32,00	44,00	92	1,00	15,00
47N716016LT	47N716016MT	16,0	16	32,00	44,00	92	2,00	15,00
47N716026LT	47N716026MT	16,0	16	32,00	44,00	92	4,00	15,00
47N720007LT	47N720007MT	20,0	20	38,00	55,00	104	1,00	19,00
47N720017LT	47N720017MT	20,0	20	38,00	55,00	104	2,00	19,00
47N720027LT	47N720027MT	20,0	20	38,00	55,00	104	4,00	19,00

Series 47N7 ALTIN • VariMill I

Material Group				TIALN			Recommended feed per tooth (fz=mm/th) for side milling (A). For slotting (B), reduce fz by 10%.								
	A		B	Cutting Speed – vc m/min			D1 – Diameter								
	ap	ae	ap	min	–	max	mm	4,0	6,0	8,0	10,0	12,0	16,0	20,0	
				min	–	max	mm	4,0	6,0	8,0	10,0	12,0	16,0	20,0	
P	1	1,5 x D	0,5 x D	1 x D	150	–	200	fz	0,028	0,044	0,060	0,072	0,083	0,101	0,114
	2	1,5 x D	0,5 x D	1 x D	140	–	190	fz	0,028	0,044	0,060	0,072	0,083	0,101	0,114
	3	1,5 x D	0,5 x D	1 x D	120	–	160	fz	0,023	0,036	0,050	0,061	0,070	0,087	0,101
	4	1,5 x D	0,5 x D	0,75 x D	90	–	150	fz	0,021	0,033	0,045	0,054	0,062	0,077	0,088
	5	1,5 x D	0,5 x D	1 x D	60	–	100	fz	0,019	0,029	0,040	0,048	0,056	0,070	0,081
	6	1,5 x D	0,5 x D	0,75 x D	50	–	75	fz	0,016	0,025	0,034	0,040	0,047	0,057	0,065
M	1	1,5 x D	0,5 x D	1 x D	90	–	115	fz	0,023	0,036	0,050	0,061	0,070	0,087	0,101
	2	1,5 x D	0,5 x D	1 x D	60	–	80	fz	0,019	0,029	0,040	0,048	0,056	0,070	0,081
	3	1,5 x D	0,5 x D	1 x D	60	–	70	fz	0,016	0,025	0,034	0,040	0,047	0,057	0,065
K	1	1,5 x D	0,5 x D	1 x D	120	–	150	fz	0,028	0,044	0,060	0,072	0,083	0,101	0,114
	2	1,5 x D	0,5 x D	1 x D	110	–	130	fz	0,023	0,036	0,050	0,061	0,070	0,087	0,101
	3	1,5 x D	0,5 x D	1 x D	100	–	130	fz	0,019	0,029	0,040	0,048	0,056	0,070	0,081
S	1	1,5 x D	0,3 x D	0,3 x D	50	–	90	fz	0,023	0,036	0,050	0,061	0,070	0,087	0,101
	2	1,5 x D	0,3 x D	0,3 x D	25	–	40	fz	0,013	0,019	0,026	0,032	0,037	0,046	0,054
	3	1,5 x D	0,5 x D	1 x D	60	–	80	fz	0,019	0,029	0,040	0,048	0,056	0,070	0,081
	4	1,5 x D	0,5 x D	1 x D	50	–	60	fz	0,016	0,026	0,037	0,045	0,052	0,064	0,074
H	1	1,5 x D	0,5 x D	0,75 x D	80	–	140	fz	0,021	0,033	0,045	0,054	0,062	0,077	0,088

NOTE: Lower value of cutting speed is used for high stock removal applications or for higher hardness (machinability) within group.

Higher value of cutting speed is used for finishing applications or for lower hardness (machinability) within group.

Above parameters are based on ideal conditions. For smaller taper machining centres, please adjust parameters accordingly on >12mm diameters.

■ Series 47N7 • Trochoidal Milling/Peel Milling

ae/D	50% ae	40% ae	30% ae	20% ae	10% ae	5% ae	4% ae	2% ae
Speed factors v_c	1	1.1	1.2	1.3	1.4	2.5	3	4
Feed factors f_z	1	1	1.1	1.4	2	2.5	3	4.4
ϕ [°]	90	78.46	66.42	53.13	36.87	25.84	23.07	16.26

Material Group	Cutting Speed – v_c m/min	D	4	6	8	10	12	16	20	25		
P	1	v_c max [m/min]	vf	16488	17273	17666	16959	16292	14869	13426	11683	mm/min
		600	n	47746	31831	23873	19099	15915	11937	9549	7639	min ⁻¹
	2	v_c max [m/min]	vf	15663	16409	16782	16111	15477	14125	12755	11099	mm/min
		570	n	45359	30239	22680	18144	15120	11340	9072	7257	min ⁻¹
	3	v_c max [m/min]	vf	11668	12224	12502	12002	11529	10522	9501	8268	mm/min
		480	n	38197	25465	19099	15279	12732	9549	7639	6112	min ⁻¹
	4	v_c max [m/min]	vf	9512	9965	10192	9784	9399	8578	7746	6740	mm/min
		450	n	35810	23873	17905	14324	11937	8952	7162	5730	min ⁻¹
	5	v_c max [m/min]	vf	5707	5979	6115	5870	5639	5147	4647	4044	mm/min
		300	n	23873	15915	11937	9549	7958	5968	4775	3820	min ⁻¹
	6	v_c max [m/min]	vf	3567	3737	3822	3669	3525	3217	2905	2528	mm/min
		225	n	17905	11937	8952	7162	5968	4476	3581	2865	min ⁻¹
M	1	v_c max [m/min]	vf	8387	8786	8986	8626	8287	7563	6829	5943	mm/min
		345	n	27454	18303	13727	10982	9151	6864	5491	4393	min ⁻¹
	2	v_c max [m/min]	vf	4566	4783	4892	4696	4512	4117	3718	3235	mm/min
		240	n	19099	12732	9549	7639	6366	4775	3820	3056	min ⁻¹
	3	v_c max [m/min]	vf	3329	3488	3567	3424	3290	3002	2711	2359	mm/min
		210	n	16711	11141	8356	6685	5570	4178	3342	2674	min ⁻¹
K	1	v_c max [m/min]	vf	12366	12955	13249	12719	12219	11151	10069	8762	mm/min
		450	n	35810	23873	17905	14324	11937	8952	7162	5730	min ⁻¹
	2	v_c max [m/min]	vf	9481	9932	10158	9751	9368	8549	7720	6718	mm/min
		390	n	31035	20690	15518	12414	10345	7759	6207	4966	min ⁻¹
	3	v_c max [m/min]	vf	7420	7773	7949	7632	7331	6691	6042	5257	mm/min
		390	n	31035	20690	15518	12414	10345	7759	6207	4966	min ⁻¹
S	1	v_c max [m/min]	vf	6563	6876	7032	6751	6485	5919	5345	4651	mm/min
		270	n	21486	14324	10743	8594	7162	5371	4297	3438	min ⁻¹
	2	v_c max [m/min]	vf	1522	1594	1631	1565	1504	1372	1239	1078	mm/min
		120	n	9549	6366	4775	3820	3183	2387	1910	1528	min ⁻¹
	3	v_c max [m/min]	vf	4566	4783	4892	4696	4512	4117	3718	3235	mm/min
		240	n	19099	12732	9549	7639	6366	4775	3820	3056	min ⁻¹
	4	v_c max [m/min]	vf	3044	3189	3261	3131	3008	2745	2479	2157	mm/min
		180	n	14324	9549	7162	5730	4775	3581	2865	2292	min ⁻¹
H	1	v_c max [m/min]	vf	8878	9301	9512	9132	8772	8006	7229	6291	mm/min
		420	n	33423	22282	16711	13369	11141	8356	6685	5348	min ⁻¹

NOTE: For all other combinations of width and depth of cut, feed and speed must be adapted.
Cutting data, which are shown in this catalogue, are applicable under optimum conditions and chip evacuation.

Recommended ae: 0,04 x D, ϕ ~23°, a_p = a_p max
Speed and feed: 4% ae

- Unequal flute spacing.
- Centre cutting.
- Single tool for both roughing and finishing operations requiring fewer setups.
- Standard items listed. Additional styles and coatings made to order.

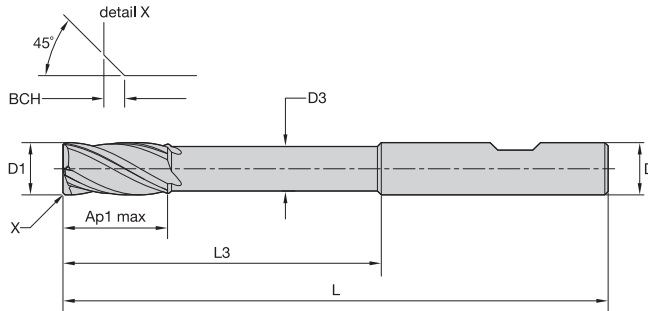
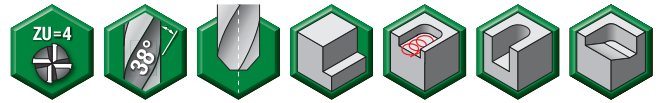
End Mill Tolerances

D1	tolerance e8	D	tolerance h6 + / -
≤ 3	-0,014/-0,028	≤ 3	0/0,006
> 3-6	-0,020/-0,038	> 3-6	0/0,008
> 6-10	-0,025/-0,047	> 6-10	0/0,009
> 10-18	-0,032/-0,059	> 10-18	0/0,011
> 18-30	-0,040/-0,073	> 18-30	0/0,013

TIALN	P						M			K			S				H	
	1	2	3	4	5	6	1	2	3	1	2	3	1	2	3	4	1	
	●	●	●	●	○	○	●	●	●	○	○	○	●	○	○	○	○	●

P – Steels

K – Cast Iron

S – High-Temp Alloys

M – Stainless Steels

N – Non-Ferrous

H – Hard Materials

For application data, see page 28.

Series 47N6 • VariMill I • Extended Reach with Neck

TIALN-LW	D1	D	length of cut Ap1 max	L3	length L	BCH	D3
47N606002LW	6,0	6	12,00	42,00	100	0,40	5,50
47N608003LW	8,0	8	16,00	62,00	100	0,40	7,30
47N610004LW	10,0	10	20,00	60,00	100	0,50	9,10
47N612005LW	12,0	12	24,00	73,00	125	0,50	11,00
47N616006LW	16,0	16	32,00	100,00	150	0,50	14,56
47N620007LW	20,0	20	40,00	98,00	175	0,50	18,20

■ Series 47N6 • VariMill I

Material Group														
		Side Milling (A) and Slotting (B)			TIALN			Recommended feed per tooth (fz=mm/th) for side milling (A). For slotting (B), reduce fz by 10%.						
		A		B	Cutting Speed – vc m/min			D1 – Diameter						
		ap	ae	ap	min		max	mm	6,0	8,0	10,0	12,0	16,0	20,0
P	1	1,5 x D	0,5 x D	1 x D	150	–	200	fz	0,044	0,060	0,072	0,083	0,101	0,114
	2	1,5 x D	0,5 x D	1 x D	140	–	190	fz	0,044	0,060	0,072	0,083	0,101	0,114
	3	1,5 x D	0,5 x D	1 x D	120	–	160	fz	0,036	0,050	0,061	0,070	0,087	0,101
	4	1,5 x D	0,5 x D	0,75 x D	90	–	150	fz	0,033	0,045	0,054	0,062	0,077	0,088
	5	1,5 x D	0,5 x D	1 x D	60	–	100	fz	0,029	0,040	0,048	0,056	0,070	0,081
	6	1,5 x D	0,5 x D	0,75 x D	50	–	75	fz	0,025	0,034	0,040	0,047	0,057	0,065
M	1	1,5 x D	0,5 x D	1 x D	90	–	115	fz	0,036	0,050	0,061	0,070	0,087	0,101
	2	1,5 x D	0,5 x D	1 x D	60	–	80	fz	0,029	0,040	0,048	0,056	0,070	0,081
	3	1,5 x D	0,5 x D	1 x D	60	–	70	fz	0,025	0,034	0,040	0,047	0,057	0,065
K	1	1,5 x D	0,5 x D	1 x D	120	–	150	fz	0,044	0,060	0,072	0,083	0,101	0,114
	2	1,5 x D	0,5 x D	1 x D	110	–	130	fz	0,036	0,050	0,061	0,070	0,087	0,101
	3	1,5 x D	0,5 x D	1 x D	100	–	130	fz	0,029	0,040	0,048	0,056	0,070	0,081
S	1	1,5 x D	0,3 x D	0,3 x D	50	–	90	fz	0,036	0,050	0,061	0,070	0,087	0,101
	2	1,5 x D	0,3 x D	0,3 x D	25	–	40	fz	0,019	0,026	0,032	0,037	0,046	0,054
	3	1,5 x D	0,5 x D	1 x D	60	–	80	fz	0,029	0,040	0,048	0,056	0,070	0,081
	4	1,5 x D	0,5 x D	1 x D	50	–	60	fz	0,026	0,037	0,045	0,052	0,064	0,074
H	1	1,5 x D	0,5 x D	0,75 x D	80	–	140	fz	0,033	0,045	0,054	0,062	0,077	0,088

NOTE: Lower value of cutting speed is used for high stock removal applications or for higher hardness (machinability) within group.
Higher value of cutting speed is used for finishing applications or for lower hardness (machinability) within group.
Above parameters are based on ideal conditions. For smaller taper machining centres, please adjust parameters accordingly on >12mm diameters.

■ Series 47N6 • Trochoidal Milling/Peel Milling

ae/D	5% ae	4% ae	2% ae
Speed factors vc	2.5	3	4
Feed factors fz	2.5	3	4.4
phi [°]	25.84	23.07	16.26

Material Group	Cutting Speed — vc m/min	D	4	6	8	10	12	16	20	25		
P	1	vc max [m/min]	vf	14747	15449	15801	15169	14572	13299	12008	10449	mm/min
		600	n	47746	31831	23873	19099	15915	11937	9549	7639	min ⁻¹
	2	vc max [m/min]	vf	14010	14677	15011	14410	13843	12634	11408	9927	mm/min
		570	n	45359	30239	22680	18144	15120	11340	9072	7257	min ⁻¹
	3	vc max [m/min]	vf	10436	10933	11182	10735	10312	9411	8498	7395	mm/min
		480	n	38197	25465	19099	15279	12732	9549	7639	6112	min ⁻¹
	4	vc max [m/min]	vf	8508	8913	9116	8751	8407	7672	6928	6029	mm/min
		450	n	35810	23873	17905	14324	11937	8952	7162	5730	min ⁻¹
	5	vc max [m/min]	vf	5105	5348	5469	5251	5044	4603	4157	3617	mm/min
		300	n	23873	15915	11937	9549	7958	5968	4775	3820	min ⁻¹
	6	vc max [m/min]	vf	3190	3342	3418	3282	3153	2877	2598	2261	mm/min
		225	n	17905	11937	8952	7162	5968	4476	3581	2865	min ⁻¹
M	1	vc max [m/min]	vf	7501	7858	8037	7716	7412	6764	6108	5315	mm/min
		345	n	27454	18303	13727	10982	9151	6864	5491	4393	min ⁻¹
	2	vc max [m/min]	vf	4084	4278	4376	4201	4035	3683	3325	2894	mm/min
		240	n	19099	12732	9549	7639	6366	4775	3820	3056	min ⁻¹
	3	vc max [m/min]	vf	2978	3120	3190	3063	2942	2685	2425	2110	mm/min
		210	n	16711	11141	8356	6685	5570	4178	3342	2674	min ⁻¹
K	1	vc max [m/min]	vf	11060	11587	11850	11376	10929	9974	9006	7837	mm/min
		450	n	35810	23873	17905	14324	11937	8952	7162	5730	min ⁻¹
	2	vc max [m/min]	vf	8480	8883	9085	8722	8379	7647	6905	6008	mm/min
		390	n	31035	20690	15518	12414	10345	7759	6207	4966	min ⁻¹
	3	vc max [m/min]	vf	6636	6952	7110	6826	6557	5984	5404	4702	mm/min
		390	n	31035	20690	15518	12414	10345	7759	6207	4966	min ⁻¹
S	1	vc max [m/min]	vf	5871	6150	6290	6038	5801	5294	4780	4160	mm/min
		270	n	21486	14324	10743	8594	7162	5371	4297	3438	min ⁻¹
	2	vc max [m/min]	vf	1361	1426	1459	1400	1345	1228	1108	965	mm/min
		120	n	9549	6366	4775	3820	3183	2387	1910	1528	min ⁻¹
	3	vc max [m/min]	vf	4084	4278	4376	4201	4035	3683	3325	2894	mm/min
		240	n	19099	12732	9549	7639	6366	4775	3820	3056	min ⁻¹
	4	vc max [m/min]	vf	2723	2852	2917	2800	2690	2455	2217	1929	mm/min
		180	n	14324	9549	7162	5730	4775	3581	2865	2292	min ⁻¹
H	1	vc max [m/min]	vf	7941	8319	8508	8168	7846	7161	6466	5627	mm/min
		420	n	33423	22282	16711	13369	11141	8356	6685	5348	min ⁻¹

NOTE: For all other combinations of width and depth of cut, feed and speed must be adapted.
Cutting data, which are shown in this catalogue, are applicable under optimum conditions and chip evacuation.

Recommended ae: 0,05 x D, phi~28,8°, ap = ap max

Speed and feed: 5% ae

- Unequal flute spacing.
- Centre cutting.
- Single tool for both roughing and finishing operations requiring fewer setups.
- Standard items listed. Additional styles and coatings made to order.

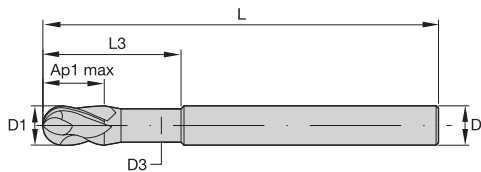
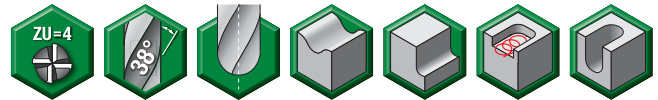

End Mill Tolerances

D1	tolerance e8	D	tolerance h6 + / -
≤ 3	-0,014/-0,028	≤ 3	0/0,006
> 3-6	-0,020/-0,038	> 3-6	0/0,008
> 6-10	-0,025/-0,047	> 6-10	0/0,009
> 10-18	-0,032/-0,059	> 10-18	0/0,011
> 18-30	-0,040/-0,073	> 18-30	0/0,013

	P						M			K			S				H
	1	2	3	4	5	6	1	2	3	1	2	3	1	2	3	4	1
TIALN	●	●	●	●	○	○	●	●	●	○	○	○	●	●	●	●	●

P – Steels K – Cast Iron S – High-Temp Alloys
M – Stainless Steels N – Non-Ferrous H – Hard Materials

For application data, see page 31.

■ Series 47N0 • VariMill™



TIALN-LT	D1	D	length of cut Ap1 max	L3	length L	D3
47N005002LT	5,0	6	9,00	15,00	57	4,70
47N006002LT	6,0	6	10,00	15,00	57	5,64
47N008003LT	8,0	8	12,00	20,00	63	7,52
47N010004LT	10,0	10	14,00	25,00	72	9,40
47N012005LT	12,0	12	16,00	30,00	83	11,28
47N016006LT	16,0	16	22,00	38,00	92	15,04
47N020007LT	20,0	20	26,00	50,00	104	18,80

Preferred approach angle for machining >3°. Avoid machining 90° to workpiece because centre is vc=0.

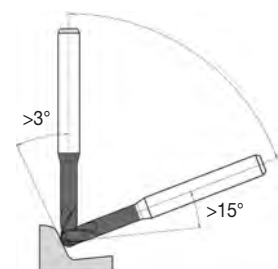
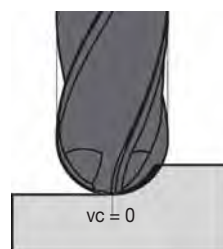

Series 47N0 • VariMill

Material Group								Recommended feed per tooth (fz=mm/th) for side milling (A). For slotting (B), reduce fz by 20%.							
	Side Milling (A) and Slotting (B)			TIALN			D1 – Diameter								
	A		B	Cutting Speed – vc m/min			mm	5,0	6,0	8,0	10,0	12,0	16,0	20,0	
	ap	ae	ap	min		max	fz								
P	1	1,5 x D	0,5 x D	1 x D	150	–	200	fz	0,036	0,044	0,060	0,072	0,083	0,101	0,114
	2	1,5 x D	0,5 x D	1 x D	140	–	190	fz	0,036	0,044	0,060	0,072	0,083	0,101	0,114
	3	1,5 x D	0,5 x D	1 x D	120	–	160	fz	0,030	0,036	0,050	0,061	0,070	0,087	0,101
	4	1,5 x D	0,5 x D	0,75 x D	90	–	150	fz	0,027	0,033	0,045	0,054	0,062	0,077	0,088
	5	1,5 x D	0,5 x D	1 x D	60	–	100	fz	0,024	0,029	0,040	0,048	0,056	0,070	0,081
	6	1,5 x D	0,5 x D	0,75 x D	50	–	75	fz	0,020	0,025	0,034	0,040	0,047	0,057	0,065
M	1	1,5 x D	0,5 x D	1 x D	90	–	115	fz	0,030	0,036	0,050	0,061	0,070	0,087	0,101
	2	1,5 x D	0,5 x D	1 x D	60	–	80	fz	0,024	0,029	0,040	0,048	0,056	0,070	0,081
	3	1,5 x D	0,5 x D	1 x D	60	–	70	fz	0,020	0,025	0,034	0,040	0,047	0,057	0,065
K	1	1,5 x D	0,5 x D	1 x D	120	–	150	fz	0,036	0,044	0,060	0,072	0,083	0,101	0,114
	2	1,5 x D	0,5 x D	1 x D	110	–	130	fz	0,030	0,036	0,050	0,061	0,070	0,087	0,101
	3	1,5 x D	0,5 x D	1 x D	100	–	130	fz	0,024	0,029	0,040	0,048	0,056	0,070	0,081
S	1	1,5 x D	0,3 x D	0,3 x D	50	–	90	fz	0,030	0,036	0,050	0,061	0,070	0,087	0,101
	2	1,5 x D	0,3 x D	0,3 x D	25	–	40	fz	0,016	0,019	0,026	0,032	0,037	0,046	0,054
	3	1,5 x D	0,5 x D	1 x D	60	–	80	fz	0,024	0,029	0,040	0,048	0,056	0,070	0,081
	4	1,5 x D	0,5 x D	1 x D	50	–	60	fz	0,021	0,026	0,037	0,045	0,052	0,064	0,074
H	1	1,5 x D	0,5 x D	0,75 x D	80	–	140	fz	0,027	0,033	0,045	0,054	0,062	0,077	0,088

NOTE: Lower value of cutting speed is used for high-stock removal applications or for higher hardness (machinability) within group.

Higher value of cutting speed is used for finishing applications or for lower hardness (machinability) within group.

Above parameters are based on ideal conditions. For smaller taper machining centres, please adjust parameters accordingly on >12mm diameters.

VariMill II™ • High-Performance Solid Carbide End Mills

VariMill II end mills are the proven leaders in the field of high-performance, chatter-free machining, designed to provide maximum metal removal rates and achieve supreme surface conditions. Utilising an innovative and proprietary design with unequal flute spacing, VariMill II carbide end mills provide users with the most versatile technology available, capable of outperforming most other high-performance tools.

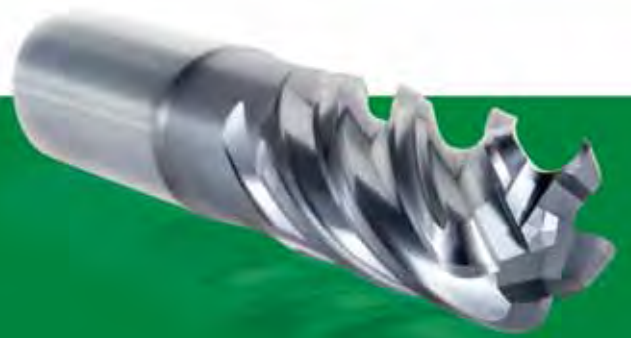

VariMill II

- 1 x D slotting in titanium and stainless steels with 5 unequally spaced flutes.
- Roughing and finishing with one tool.
- Various length of cut, necked version, corner radius versions available.

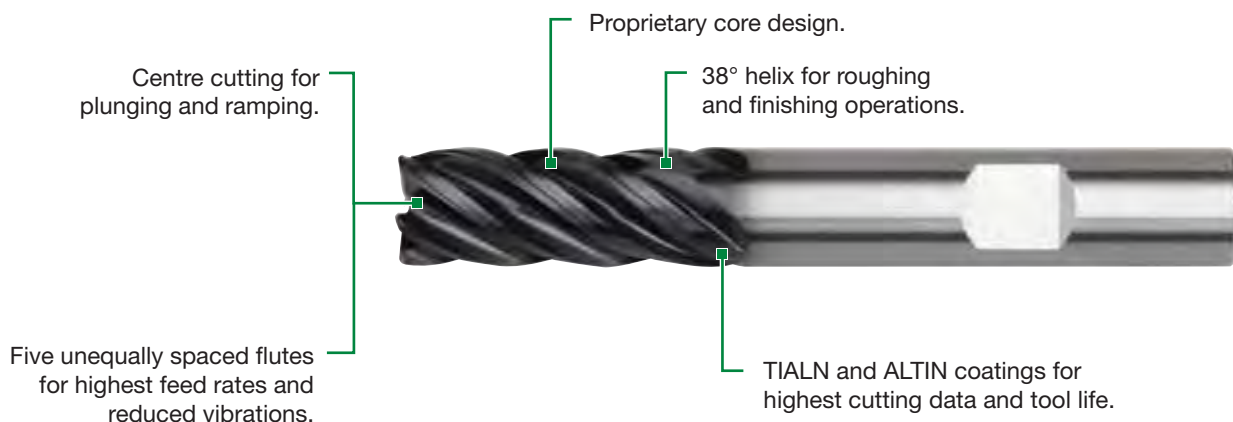

To learn more, scan here.

VariMill II™ Series

- Five unequally spaced flutes boosting your output with higher feed rates.
- Roughing and finishing with one tool.
- Less passes due to 1 x D slotting capability on almost all types of materials, even titanium.

5777 Series

- Highest Metal Removal Rates (MRR) and tool life in:
 - Stainless steels, steels and alloyed steels.
 - Cast iron.
 - High-temperature alloys and titanium.
- Corner radii and sharp edges.
- Non-centre cutting.
- Ramping up to 3°.



577C Series

- Highest Metal Removal Rates (MRR) due to 5-flute centre cutting design.
- Increased tool life with stainless steels and steels.
- Centre cutting.

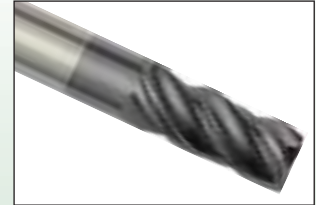

57N8 Series

- Titanium and stainless steel geometry design.
- Radii corner and neck design for depths requiring additional passes.
- Non-centre cutting.
- Ramping up to 3°.



577E Metric Series

- Extensive radii corner offering.
- Highest Metal Removal Rates (MRR) due to 5-flute centre cutting design.



57NE Metric Series

- Extensive radii corner offering.
- Neck design for depths requiring additional passes.



5718 Series

- Highest surface quality and tool life in:
 - Titanium.
 - Stainless steels.
- Corner radii and sharp edges.
- 4 x D length of cut.



- Unequal flute spacing.
- Non-centre cutting.
- Maximum ramp angle = 3°.
- Single tool for both roughing and finishing operations requiring fewer setups.
- Slotting up to 1 x D.
- Standard items listed. Additional styles and coatings made to order.

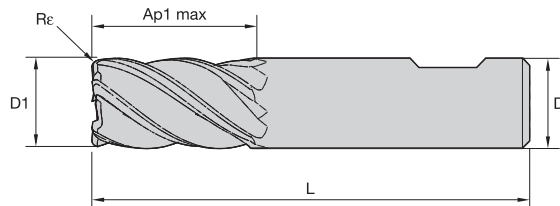
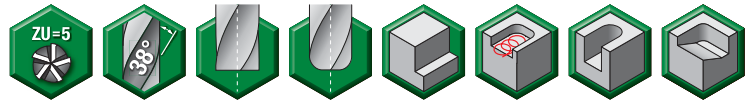

End Mill Tolerances

D1	tolerance e8	D	tolerance h6 + / -
≤ 3	-0,014/-0,028	≤ 3	0/0,006
> 3-6	-0,020/-0,038	> 3-6	0/0,008
> 6-10	-0,025/-0,047	> 6-10	0/0,009
> 10-18	-0,032/-0,059	> 10-18	0/0,011
> 18-30	-0,040/-0,073	> 18-30	0/0,013

	P						M			K			S				H	
	1	2	3	4	5	6	1	2	3	1	2	3	1	2	3	4	1	
ALTIN	●	●	●	●	●	●	●	●	●	○	○	○	●	○	○	○	○	●

P – Steels

K – Cast Iron

S – High-Temp Alloys

M – Stainless Steels

N – Non-Ferrous

H – Hard Materials

For application data, see page 38.

Series 5777 • VariMill II



ALTIN-MT	ALTIN-MW	D1	D	length of cut Ap1 max	length L	Re
577704002MT	577704002MW	4,0	6	11,00	55	0,25
577704012MT	–	4,0	6	11,00	55	–
577705002MT	577705002MW	5,0	6	13,00	57	0,25
577706002MT	577706002MW	6,0	6	13,00	57	0,40
577706012MT	–	6,0	6	13,00	57	–
577707003MT	577707003MW	7,0	8	16,00	63	0,40
577708003MT	577708003MW	8,0	8	19,00	63	0,50
577708013MT	–	8,0	8	19,00	63	–
577709004MT	–	9,0	9	19,00	72	0,50
–	577709004MW	9,0	10	19,00	72	0,50
577710004MT	577710004MW	10,0	10	22,00	72	0,50
577710014MT	–	10,0	10	22,00	72	–
577712005MT	577712005MW	12,0	12	26,00	83	0,75
577712015MT	–	12,0	12	26,00	83	–
577714004MT	577714004MW	14,0	14	26,00	83	0,75
577714014MT	–	14,0	14	26,00	83	–
577716006MT	577716006MW	16,0	16	32,00	92	0,75
577716016MT	–	16,0	16	32,00	92	–
577718008MT	577718008MW	18,0	18	32,00	92	0,75
577720007MT	577720007MW	20,0	20	38,00	104	0,75
577720017MT	–	20,0	20	38,00	104	–
577725008MT	577725008MW	25,0	25	45,00	121	0,75

- Unequal flute spacing.
- Centre cutting.
- Single tool for both roughing and finishing operations requiring fewer setups.
- Slotting up to 1 x D.
- Standard items listed. Additional styles and coatings made to order.

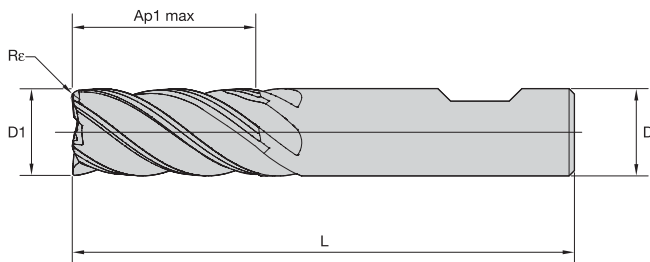
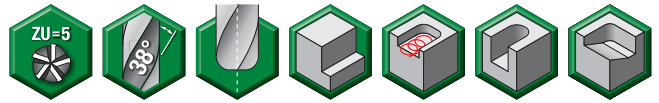
End Mill Tolerances

D1	tolerance e8	D	tolerance h6 + / -
≤ 3	-0,014/-0,028	≤ 3	0/0,006
> 3-6	-0,020/-0,038	> 3-6	0/0,008
> 6-10	-0,025/-0,047	> 6-10	0/0,009
> 10-18	-0,032/-0,059	> 10-18	0/0,011
> 18-30	-0,040/-0,073	> 18-30	0/0,013

	P						M			K			S				H	
	1	2	3	4	5	6	1	2	3	1	2	3	1	2	3	4	1	
ALTIN-MW	●	●	●	●	●	●	●	●	●	○	○	○	●	○	○	○	○	●

P – Steels *K – Cast Iron* *S – High-Temp Alloys*
M – Stainless Steels *N – Non-Ferrous* *H – Hard Materials*

For application data, see page 38.

Series 577C • VariMill II™ • With Centre Cut

ALTIN-MW	D1	D	length of cut Ap1 max	length L	Re
577C06002MW	6,0	6	13,00	57	0,40
577C08003MW	8,0	8	16,00	63	0,50
577C10004MW	10,0	10	22,00	72	0,50
577C12005MW	12,0	12	26,00	83	0,75
577C16006MW	16,0	16	32,00	92	0,75
577C20007MW	20,0	20	38,00	104	0,75
577C25008LW	25,0	25	45,00	121	0,75

- Unequal flute spacing.
- Non-centre cutting.
- Maximum ramp angle = 3°.
- Optimised geometry for titanium machining.
- Single tool for both roughing and finishing operations requiring fewer setups.
- Slotting up to 1 x D.
- Standard items listed. Additional styles and coatings made to order.

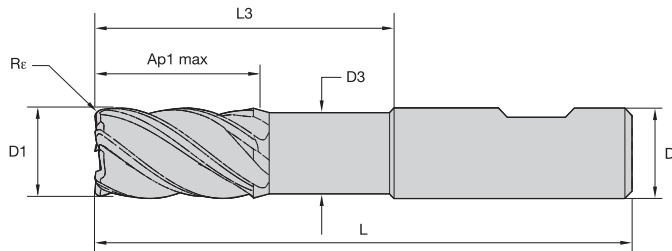
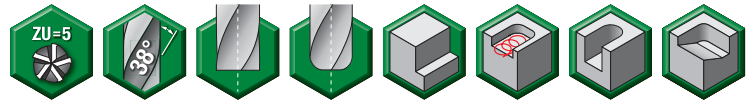

End Mill Tolerances

D1	tolerance e8	D	tolerance h6 + / -
≤ 3	-0,014/-0,028	≤ 3	0/0,006
> 3-6	-0,020/-0,038	> 3-6	0/0,008
> 6-10	-0,025/-0,047	> 6-10	0/0,009
> 10-18	-0,032/-0,059	> 10-18	0/0,011
> 18-30	-0,040/-0,073	> 18-30	0/0,013

	P						M			K			S				H			
	1	2	3	4	5	6	1	2	3	1	2	3	1	2	3	4	1			
ALTIN	●	●	○	○	●	●	○	○	○	○	○	○	○	○	○	○	●	●	●	●

P – Steels K – Cast Iron S – High-Temp Alloys
M – Stainless Steels N – Non-Ferrous H – Hard Materials

For application data, see page 39.

■ Series 57N8 • VariMill II • With Neck



ALTIN-MT	ALTIN-MW	D1	D	length of cut Ap1 max	L3	length L	Rε	D3
57N806002MT	—	6,0	6	13,00	18,00	63	—	5,60
57N806022MT	57N806022MW	6,0	6	13,00	18,00	63	0,50	5,60
57N806032MT	57N806032MW	6,0	6	13,00	18,00	63	1,00	5,60
—	57N806042MW	6,0	6	13,00	18,00	63	1,50	5,60
57N808003MT	—	8,0	8	19,00	24,00	76	—	7,50
57N808023MT	57N808023MW	8,0	8	19,00	24,00	76	0,50	7,50
57N808033MT	57N808033MW	8,0	8	19,00	24,00	76	1,00	7,50
—	57N808053MW	8,0	8	19,00	24,00	76	2,00	7,50
57N810004MT	—	10,0	10	22,00	30,00	76	—	9,40
57N810024MT	57N810024MW	10,0	10	22,00	30,00	76	0,50	9,40
57N810034MT	57N810034MW	10,0	10	22,00	30,00	76	1,00	9,40
57N810054MT	57N810054MW	10,0	10	22,00	30,00	76	2,00	9,40

(continued)

(Series 57N8 • VariMill II • With Neck – continued)

	P						M			K			S				H
	1	2	3	4	5	6	1	2	3	1	2	3	1	2	3	4	1
ALTIN	●	●	○	○	●	●	○	○	○	○	○	○	○	○	○	○	○

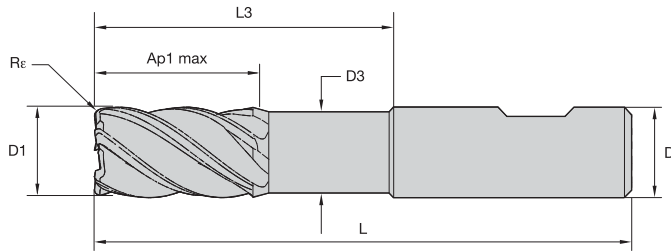

P – Steels K – Cast Iron S – High-Temp Alloys
 M – Stainless Steels N – Non-Ferrous H – Hard Materials

For application data, see page 39.





ALTIN-MT	ALTIN-MW	D1	D	length of cut Ap1 max	L3	length L	Rε	D3
57N812005MT	—	12,0	12	26,00	36,00	83	—	11,28
57N812025MT	57N812025MW	12,0	12	26,00	36,00	83	0,50	11,28
57N812035MT	57N812035MW	12,0	12	26,00	36,00	83	1,00	11,28
57N812055MT	57N812055MW	12,0	12	26,00	36,00	83	2,00	11,28
57N816006MT	—	16,0	16	32,00	48,00	100	—	15,05
57N816026MT	57N816026MW	16,0	16	32,00	48,00	100	0,50	15,05
57N816036MT	57N816036MW	16,0	16	32,00	48,00	100	1,00	15,05
57N816056MT	57N816056MW	16,0	16	32,00	48,00	100	2,00	15,05
57N816076MT	57N816076MW	16,0	16	32,00	48,00	100	3,00	15,05
57N820007MT	—	20,0	20	38,00	60,00	115	—	18,80
57N820027MT	57N820027MW	20,0	20	38,00	60,00	115	0,50	18,80
57N820037MT	57N820037MW	20,0	20	38,00	60,00	115	1,00	18,80
57N820057MT	57N820057MW	20,0	20	38,00	60,00	115	2,00	18,80
57N820077MT	57N820077MW	20,0	20	38,00	60,00	115	3,00	18,80
57N820087MT	57N820087MW	20,0	20	38,00	60,00	115	4,00	18,80
57N825008MT	—	25,0	25	45,00	75,00	135	—	23,50
57N825028MT	57N825028MW	25,0	25	45,00	75,00	135	0,50	23,50
57N825038MT	57N825038MW	25,0	25	45,00	75,00	135	1,00	23,50
57N825058MT	57N825058MW	25,0	25	45,00	75,00	135	2,00	23,50
57N825078MT	57N825078MW	25,0	25	45,00	75,00	135	3,00	23,50
57N825088MT	57N825088MW	25,0	25	45,00	75,00	135	4,00	23,50

■ Series 5777 • VariMill II

Material Group	 																
	Side Milling (A) and Slotting (B)			ALTIM			Recommended feed per tooth (fz=mm/th) for side milling (A). For slotting (B), reduce fz by 20%.										
	A		B	Cutting Speed – vc m/min			D1 – Diameter										
	ap	ae	ap	min		max	mm	4,0	6,0	8,0	10,0	12,0	16,0	20,0	25,0		
P	1	1,5 x D	0,5 x D	1 x D	150	–	200	fz	0,028	0,044	0,060	0,072	0,083	0,101	0,114	0,124	
	2	1,5 x D	0,5 x D	1 x D	140	–	190	fz	0,028	0,044	0,060	0,072	0,083	0,101	0,114	0,124	
	3	1,5 x D	0,5 x D	1 x D	120	–	160	fz	0,023	0,036	0,050	0,061	0,070	0,087	0,101	0,114	
	4	1,5 x D	0,5 x D	0,75 x D	90	–	150	fz	0,021	0,033	0,045	0,054	0,062	0,077	0,088	0,098	
	5	1,5 x D	0,5 x D	1 x D	60	–	100	fz	0,019	0,029	0,040	0,048	0,056	0,070	0,081	0,091	
	6	1,5 x D	0,5 x D	0,75 x D	50	–	75	fz	0,016	0,025	0,034	0,040	0,047	0,057	0,065	0,071	
M	1	1,5 x D	0,5 x D	1 x D	90	–	115	fz	0,023	0,036	0,050	0,061	0,070	0,087	0,101	0,114	
	2	1,5 x D	0,5 x D	1 x D	60	–	80	fz	0,019	0,029	0,040	0,048	0,056	0,070	0,081	0,091	
	3	1,5 x D	0,5 x D	1 x D	60	–	70	fz	0,016	0,025	0,034	0,040	0,047	0,057	0,065	0,071	
K	1	1,5 x D	0,5 x D	1 x D	120	–	150	fz	0,028	0,044	0,060	0,072	0,083	0,101	0,114	0,124	
	2	1,5 x D	0,5 x D	1 x D	110	–	130	fz	0,023	0,036	0,050	0,061	0,070	0,087	0,101	0,114	
	3	1,5 x D	0,5 x D	1 x D	100	–	130	fz	0,019	0,029	0,040	0,048	0,056	0,070	0,081	0,091	
S	1	1,5 x D	0,3 x D	0,3 x D	50	–	90	fz	0,023	0,036	0,050	0,061	0,070	0,087	0,101	0,114	
	2	1,5 x D	0,3 x D	0,3 x D	25	–	40	fz	0,013	0,019	0,026	0,032	0,037	0,046	0,054	0,061	
	3	1,5 x D	0,5 x D	1 x D	60	–	80	fz	0,019	0,029	0,040	0,048	0,056	0,070	0,081	0,091	
	4	1,5 x D	0,5 x D	1 x D	50	–	60	fz	0,016	0,026	0,037	0,045	0,052	0,064	0,074	0,084	
H	1	1,5 x D	0,5 x D	0,75 x D	80	–	140	fz	0,021	0,033	0,045	0,054	0,062	0,077	0,088	0,098	

NOTE: Lower value of cutting speed is used for high-stock removal applications or for higher hardness (machinability) within group.
Higher value of cutting speed is used for finishing applications or for lower hardness (machinability) within group.
Above parameters are based on ideal conditions. For smaller taper machining centres, please adjust parameters accordingly on >12mm diameters.

■ Series 577C • VariMill II

Material Group	 														
	Side Milling (A) and Slotting (B)			ALTIM			Recommended feed per tooth (fz=mm/th) for side milling (A). For slotting (B), reduce fz by 10%.								
	A		B	Cutting Speed – vc m/min			D1 – Diameter								
	ap	ae	ap	min		max	mm	6,0	8,0	10,0	12,0	16,0	20,0	25,0	
P	1	1,5 x D	0,5 x D	1 x D	150	–	200	fz	0,044	0,060	0,072	0,083	0,101	0,114	0,124
	2	1,5 x D	0,5 x D	1 x D	140	–	190	fz	0,044	0,060	0,072	0,083	0,101	0,114	0,124
	3	1,5 x D	0,5 x D	1 x D	120	–	160	fz	0,036	0,050	0,061	0,070	0,087	0,101	0,114
	4	1,5 x D	0,5 x D	0,75 x D	90	–	150	fz	0,033	0,045	0,054	0,062	0,077	0,088	0,098
	5	1,5 x D	0,5 x D	1 x D	60	–	100	fz	0,029	0,040	0,048	0,056	0,070	0,081	0,091
	6	1,5 x D	0,5 x D	0,75 x D	50	–	75	fz	0,025	0,034	0,040	0,047	0,057	0,065	0,071
M	1	1,5 x D	0,5 x D	1 x D	90	–	115	fz	0,036	0,050	0,061	0,070	0,087	0,101	0,114
	2	1,5 x D	0,5 x D	1 x D	60	–	80	fz	0,029	0,040	0,048	0,056	0,070	0,081	0,091
	3	1,5 x D	0,5 x D	1 x D	60	–	70	fz	0,025	0,034	0,040	0,047	0,057	0,065	0,071
K	1	1,5 x D	0,5 x D	1 x D	120	–	150	fz	0,044	0,060	0,072	0,083	0,101	0,114	0,124
	2	1,5 x D	0,5 x D	1 x D	110	–	130	fz	0,036	0,050	0,061	0,070	0,087	0,101	0,114
	3	1,5 x D	0,5 x D	1 x D	100	–	130	fz	0,029	0,040	0,048	0,056	0,070	0,081	0,091
S	1	1,5 x D	0,3 x D	0,3 x D	50	–	90	fz	0,036	0,050	0,061	0,070	0,087	0,101	0,114
	2	1,5 x D	0,3 x D	0,3 x D	25	–	40	fz	0,019	0,026	0,032	0,037	0,046	0,054	0,061
	3	1,5 x D	0,5 x D	1 x D	60	–	80	fz	0,029	0,040	0,048	0,056	0,070	0,081	0,091
	4	1,5 x D	0,5 x D	1 x D	50	–	60	fz	0,026	0,037	0,045	0,052	0,064	0,074	0,084
H	1	1,5 x D	0,5 x D	0,75 x D	80	–	140	fz	0,033	0,045	0,054	0,062	0,077	0,088	0,098

NOTE: Lower value of cutting speed is used for high stock removal applications or for higher hardness (machinability) within group.
Higher value of cutting speed is used for finishing applications or for lower hardness (machinability) within group.
Above parameters are based on ideal conditions. For smaller taper machining centres, please adjust parameters accordingly on >12mm diameters.

Series 57N8 • VariMill II

Material Group									Recommended feed per tooth (fz=mm/th) for side milling (A). For slotting (B), reduce fz by 20%.						
		Side Milling (A) and Slotting (B)			ALTIN										
		A		B	Cutting Speed – vc m/min			D1 – Diameter							
		ap	ae	ap	min	–	max	mm	6,0	8,0	10,0	12,0	16,0	20,0	25,0
P	1	1,5 x D	0,5 x D	1 x D	150	–	200	fz	0,044	0,060	0,072	0,083	0,101	0,114	0,124
	2	1,5 x D	0,5 x D	1 x D	140	–	190	fz	0,044	0,060	0,072	0,083	0,101	0,114	0,124
	3	1,5 x D	0,5 x D	1 x D	120	–	160	fz	0,036	0,050	0,061	0,070	0,087	0,101	0,114
	4	1,5 x D	0,5 x D	0,75 x D	90	–	150	fz	0,033	0,045	0,054	0,062	0,077	0,088	0,098
	5	1,5 x D	0,5 x D	1 x D	60	–	100	fz	0,029	0,040	0,048	0,056	0,070	0,081	0,091
	6	1,5 x D	0,5 x D	0,75 x D	50	–	75	fz	0,025	0,034	0,040	0,047	0,057	0,065	0,071
M	1	1,5 x D	0,5 x D	1 x D	90	–	115	fz	0,036	0,050	0,061	0,070	0,087	0,101	0,114
	2	1,5 x D	0,5 x D	1 x D	60	–	80	fz	0,029	0,040	0,048	0,056	0,070	0,081	0,091
	3	1,5 x D	0,5 x D	1 x D	60	–	70	fz	0,025	0,034	0,040	0,047	0,057	0,065	0,071
K	1	1,5 x D	0,5 x D	1 x D	120	–	150	fz	0,044	0,060	0,072	0,083	0,101	0,114	0,124
	2	1,5 x D	0,5 x D	1 x D	110	–	130	fz	0,036	0,050	0,061	0,070	0,087	0,101	0,114
	3	1,5 x D	0,5 x D	1 x D	100	–	130	fz	0,029	0,040	0,048	0,056	0,070	0,081	0,091
S	1	1,5 x D	0,3 x D	0,3 x D	50	–	90	fz	0,036	0,050	0,061	0,070	0,087	0,101	0,114
	2	1,5 x D	0,3 x D	0,3 x D	25	–	40	fz	0,019	0,026	0,032	0,037	0,046	0,054	0,061
	3	1,5 x D	0,5 x D	1 x D	60	–	80	fz	0,029	0,040	0,048	0,056	0,070	0,081	0,091
	4	1,5 x D	0,5 x D	1 x D	50	–	60	fz	0,026	0,037	0,045	0,052	0,064	0,074	0,084
H	1	1,5 x D	0,5 x D	0,75 x D	80	–	140	fz	0,033	0,045	0,054	0,062	0,077	0,088	0,098

NOTE: Lower value of cutting speed is used for high-stock removal applications or for higher hardness (machinability) within group.

Higher value of cutting speed is used for finishing applications or for lower hardness (machinability) within group.

Above parameters are based on ideal conditions. For smaller taper machining centres, please adjust parameters accordingly on diameters >12mm diameters.

■ Series 5777 577C 57N8 • Trochoidal Milling/Peel Milling

ae/D	Full Slot	50% ae	40% ae	30% ae	20% ae	10% ae	5% ae	4% ae	2% ae
Speed factors vc	0.9	1	1.1	1.2	1.3	1.4	2.5	3	4
Feed factors fz	0.8	1	1	1.1	1.4	2	2.5	3	4.4
phi [°]	180	90	78.46	66.42	53.13	36.87	25.84	23.07	16.26

Material Group	Cutting Speed – vc m/min	D	4	6	8	10	12	16	20	25		
P	1	vc max [m/min]	vf	20610	21591	22082	21199	20364	18586	16782	14604	mm/min
		600	n	47746	31831	23873	19099	15915	11937	9549	7639	min ⁻¹
	2	vc max [m/min]	vf	19579	20512	20978	20139	19346	17656	15943	13873	mm/min
		570	n	45359	30239	22680	18144	15120	11340	9072	7257	min ⁻¹
	3	vc max [m/min]	vf	14585	15280	15627	15002	14412	13153	11877	10335	mm/min
		480	n	38197	25465	19099	15279	12732	9549	7639	6112	min ⁻¹
	4	vc max [m/min]	vf	11890	12456	12740	12230	11749	10722	9682	8425	mm/min
		450	n	35810	23873	17905	14324	11937	8952	7162	5730	min ⁻¹
	5	vc max [m/min]	vf	7134	7474	7644	7338	7049	6433	5809	5055	mm/min
		300	n	23873	15915	11937	9549	7958	5968	4775	3820	min ⁻¹
	6	vc max [m/min]	vf	4459	4671	4777	4586	4406	4021	3631	3159	mm/min
		225	n	17905	11937	8952	7162	5968	4476	3581	2865	min ⁻¹
M	1	vc max [m/min]	vf	10483	10982	11232	10783	10358	9454	8536	7428	mm/min
		345	n	27454	18303	13727	10982	9151	6864	5491	4393	min ⁻¹
	2	vc max [m/min]	vf	5707	5979	6115	5870	5639	5147	4647	4044	mm/min
		240	n	19099	12732	9549	7639	6366	4775	3820	3056	min ⁻¹
	3	vc max [m/min]	vf	4162	4360	4459	4280	4112	3753	3389	2949	mm/min
		210	n	16711	11141	8356	6685	5570	4178	3342	2674	min ⁻¹
K	1	vc max [m/min]	vf	15457	16193	16561	15899	15273	13939	12587	10953	mm/min
		450	n	35810	23873	17905	14324	11937	8952	7162	5730	min ⁻¹
	2	vc max [m/min]	vf	11851	12415	12697	12189	11710	10687	9650	8397	mm/min
		390	n	31035	20690	15518	12414	10345	7759	6207	4966	min ⁻¹
	3	vc max [m/min]	vf	9274	9716	9937	9539	9164	8364	7552	6572	mm/min
		390	n	31035	20690	15518	12414	10345	7759	6207	4966	min ⁻¹
S	1	vc max [m/min]	vf	8204	8595	8790	8439	8107	7399	6681	5813	mm/min
		270	n	21486	14324	10743	8594	7162	5371	4297	3438	min ⁻¹
	2	vc max [m/min]	vf	1902	1993	2038	1957	1880	1716	1549	1348	mm/min
		120	n	9549	6366	4775	3820	3183	2387	1910	1528	min ⁻¹
	3	vc max [m/min]	vf	5707	5979	6115	5870	5639	5147	4647	4044	mm/min
		240	n	19099	12732	9549	7639	6366	4775	3820	3056	min ⁻¹
	4	vc max [m/min]	vf	3805	3986	4077	3914	3760	3431	3098	2696	mm/min
		180	n	14324	9549	7162	5730	4775	3581	2865	2292	min ⁻¹
H	1	vc max [m/min]	vf	11098	11626	11890	11415	10965	10008	9037	7863	mm/min
		420	n	33423	22282	16711	13369	11141	8356	6685	5348	min ⁻¹

NOTE: For all other combinations of width and depth of cut, feed and speed must be adapted.
 Cutting data, which are shown in this catalogue, are applicable under optimum conditions and chip evacuation.

Recommended ae: 0,04 x D, phi-23°, ap = ap max

Speed and feed: 4% ae

- Unequal flute spacing.
- Centre cutting.
- Optimised geometry for titanium machining.
- Single tool for both roughing and finishing operations requiring fewer setups.
- Standard items listed. Additional styles and coatings made to order.

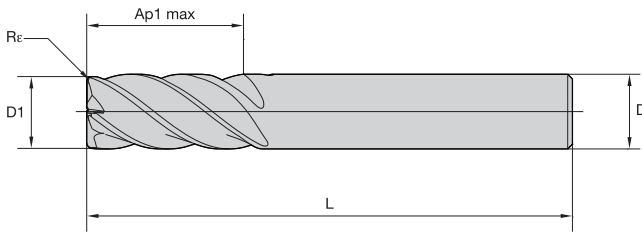
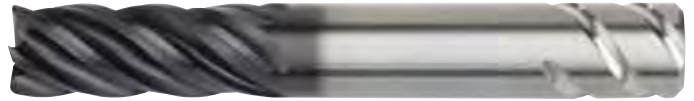
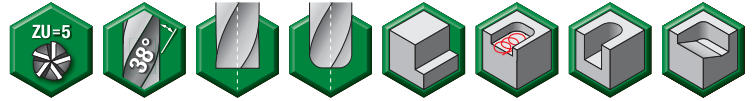
End Mill Tolerances

D1	tolerance e8	D	tolerance h6 + / -
≤ 3	-0,014/-0,028	≤ 3	0/0,006
> 3-6	-0,020/-0,038	> 3-6	0/0,008
> 6-10	-0,025/-0,047	> 6-10	0/0,009
> 10-18	-0,032/-0,059	> 10-18	0/0,011
> 18-30	-0,040/-0,073	> 18-30	0/0,013

ALTIN	P						M			K			S				H
	1	2	3	4	5	6	1	2	3	1	2	3	1	2	3	4	1
ALTIN	●	●	○	○	●	●	●	●	●	○	○	○	●	●	●	●	●

P – Steels K – Cast Iron S – High-Temp Alloys
M – Stainless Steels N – Non-Ferrous H – Hard Materials

For application data, see page 43.

Series 577E • VariMill II™ ER

ALTIN-MT	ALTIN-MV	ALTIN-MW	D1	D	length of cut Ap1 max	length L	Re
577E10004MT	–	–	10,0	10	22,00	72	–
577E10024MT	–	577E10024MW	10,0	10	22,00	72	0,50
–	577E12005MV	–	12,0	12	26,00	83	–
–	577E12015MV	577E12015MW	12,0	12	26,00	83	0,75
–	577E16006MV	–	16,0	16	32,00	92	–
–	577E16016MV	577E16016MW	16,0	16	32,00	92	0,75
–	577E20007MV	–	20,0	20	38,00	104	–
–	577E20017MV	577E20017MW	20,0	20	38,00	104	0,75
–	577E25018MV	577E25018MW	25,0	25	45,00	121	0,75

- Unequal flute spacing.
- Centre cutting.
- Optimised geometry for titanium machining.
- Single tool for both roughing and finishing operations requiring fewer setups.
- Standard items listed. Additional styles and coatings made to order.

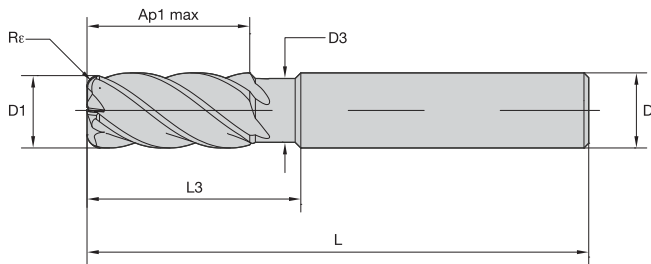
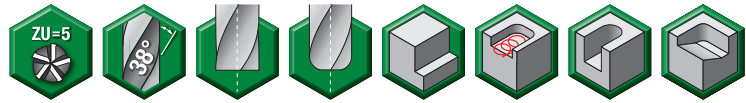

End Mill Tolerances

D1	tolerance e8	D	tolerance h6 + / -
≤ 3	-0,014/-0,028	≤ 3	0/0,006
> 3-6	-0,020/-0,038	> 3-6	0/0,008
> 6-10	-0,025/-0,047	> 6-10	0/0,009
> 10-18	-0,032/-0,059	> 10-18	0/0,011
> 18-30	-0,040/-0,073	> 18-30	0/0,013

ALTIN	P						M			K			S				H
	1	2	3	4	5	6	1	2	3	1	2	3	1	2	3	4	1
ALTIN	●	●	○	○	●	●	●	●	●	○	○	○	●	●	●	●	●

P – Steels K – Cast Iron S – High-Temp Alloys
M – Stainless Steels N – Non-Ferrous H – Hard Materials

For application data, see page 43.

■ Series 57NE • VariMill II™ ER • With Neck



ALTIN-MT	ALTIN-MV	ALTIN-MW	D1	D	length of cut Ap1 max	L3	length L	Re	D3
57NE10004MT	—	—	10,0	10	22,00	30,00	76	—	9,40
57NE10024MT	—	57NE10024MW	10,0	10	22,00	30,00	76	0,50	9,40
57NE10034MT	—	57NE10034MW	10,0	10	22,00	30,00	76	1,00	9,40
57NE10054MT	—	57NE10054MW	10,0	10	22,00	30,00	76	2,00	9,40
—	57NE12005MV	—	12,0	12	26,00	36,00	83	—	11,28
—	57NE12025MV	57NE12025MW	12,0	12	26,00	36,00	83	0,50	11,28
—	57NE12035MV	57NE12035MW	12,0	12	26,00	36,00	83	1,00	11,28
—	57NE12055MV	57NE12055MW	12,0	12	26,00	36,00	83	2,00	11,28
—	57NE16006MV	—	16,0	16	32,00	48,00	100	—	15,04
—	57NE16026MV	57NE16026MW	16,0	16	32,00	48,00	100	0,50	15,04
—	57NE16036MV	57NE16036MW	16,0	16	32,00	48,00	100	1,00	15,04
—	57NE16056MV	57NE16056MW	16,0	16	32,00	48,00	100	2,00	15,04
—	57NE20007MV	—	20,0	20	38,00	60,00	115	—	18,80
—	57NE20027MV	57NE20027MW	20,0	20	38,00	60,00	115	0,50	18,80
—	57NE20037MV	57NE20037MW	20,0	20	38,00	60,00	115	1,00	18,80
—	57NE20057MV	—	20,0	20	38,00	22,00	115	2,00	18,80
—	—	57NE20057MW	20,0	20	38,00	60,00	115	2,00	18,80
—	57NE20087MV	57NE20087MW	20,0	20	38,00	60,00	115	4,00	18,80
—	57NE25008MV	—	25,0	25	45,00	75,00	135	—	23,50
—	57NE25028MV	57NE25028MW	25,0	25	45,00	75,00	135	0,50	23,50
—	57NE25038MV	57NE25038MW	25,0	25	45,00	75,00	135	1,00	23,50
—	57NE25058MV	57NE25058MW	25,0	25	45,00	75,00	135	2,00	23,50
—	57NE25088MV	57NE25088MW	25,0	25	45,00	75,00	135	4,00	23,50

Series 577E • VariMill II ER

Material Group									Side Milling (A) and Slotting (B)				
		Side Milling (A) and Slotting (B)			ALTiN			Recommended feed per tooth (fz=mm/th) for side milling (A). For slotting (B), reduce fz by 20%.					
		A		B	Cutting Speed – vc m/min			mm	D1 – Diameter				
		ap	ae	ap	min		max		10,0	12,0	16,0	20,0	25,0
P	1	1,5 x D	0,5 x D	1 x D	150	–	200	fz	0,072	0,083	0,101	0,114	0,124
	2	1,5 x D	0,5 x D	1 x D	140	–	190	fz	0,072	0,083	0,101	0,114	0,124
	3	1,5 x D	0,5 x D	1 x D	120	–	160	fz	0,061	0,070	0,087	0,101	0,114
	4	1,5 x D	0,5 x D	0,75 x D	90	–	150	fz	0,054	0,062	0,077	0,088	0,098
	5	1,5 x D	0,5 x D	1 x D	60	–	100	fz	0,048	0,056	0,070	0,081	0,091
	6	1,5 x D	0,5 x D	0,75 x D	50	–	75	fz	0,040	0,047	0,057	0,065	0,071
M	1	1,5 x D	0,5 x D	1 x D	90	–	115	fz	0,061	0,070	0,087	0,101	0,114
	2	1,5 x D	0,5 x D	1 x D	60	–	80	fz	0,048	0,056	0,070	0,081	0,091
	3	1,5 x D	0,5 x D	1 x D	60	–	70	fz	0,040	0,047	0,057	0,065	0,071
K	1	1,5 x D	0,5 x D	1 x D	120	–	150	fz	0,072	0,083	0,101	0,114	0,124
	2	1,5 x D	0,5 x D	1 x D	110	–	130	fz	0,061	0,070	0,087	0,101	0,114
	3	1,5 x D	0,5 x D	1 x D	110	–	130	fz	0,048	0,056	0,070	0,081	0,091
S	1	1,5 x D	0,3 x D	0,3 x D	50	–	90	fz	0,061	0,070	0,087	0,101	0,114
	2	1,5 x D	0,3 x D	0,3 x D	25	–	40	fz	0,032	0,037	0,046	0,054	0,061
	3	1,5 x D	0,5 x D	1 x D	60	–	80	fz	0,048	0,056	0,070	0,081	0,091
	4	1,5 x D	0,5 x D	1 x D	50	–	60	fz	0,045	0,052	0,064	0,074	0,084
H	1	1,5 x D	0,5 x D	0,75 x D	80	–	140	fz	0,054	0,062	0,077	0,088	0,098

Series 57NE • VariMill II ER

Material Group									Side Milling (A) and Slotting (B)				
		Side Milling (A) and Slotting (B)			ALTiN			Recommended feed per tooth (fz=mm/th) for side milling (A). For slotting (B), reduce fz by 20%.					
		A		B	Cutting Speed – vc m/min			mm	D1 – Diameter				
		ap	ae	ap	min		max		10,0	12,0	16,0	20,0	25,0
P	1	1,5 x D	0,5 x D	1 x D	150	–	200	fz	0,072	0,083	0,101	0,114	0,124
	2	1,5 x D	0,5 x D	1 x D	140	–	190	fz	0,072	0,083	0,101	0,114	0,124
	3	1,5 x D	0,5 x D	1 x D	120	–	160	fz	0,061	0,070	0,087	0,101	0,114
	4	1,5 x D	0,5 x D	0,75 x D	90	–	150	fz	0,054	0,062	0,077	0,088	0,098
	5	1,5 x D	0,5 x D	1 x D	60	–	100	fz	0,048	0,056	0,070	0,081	0,091
	6	1,5 x D	0,5 x D	0,75 x D	50	–	75	fz	0,040	0,047	0,057	0,065	0,071
M	1	1,5 x D	0,5 x D	1 x D	90	–	115	fz	0,061	0,070	0,087	0,101	0,114
	2	1,5 x D	0,5 x D	1 x D	60	–	80	fz	0,048	0,056	0,070	0,081	0,091
	3	1,5 x D	0,5 x D	1 x D	60	–	70	fz	0,040	0,047	0,057	0,065	0,071
K	1	1,5 x D	0,5 x D	1 x D	120	–	150	fz	0,072	0,083	0,101	0,114	0,124
	2	1,5 x D	0,5 x D	1 x D	110	–	130	fz	0,061	0,070	0,087	0,101	0,114
	3	1,5 x D	0,5 x D	1 x D	110	–	130	fz	0,048	0,056	0,070	0,081	0,091
S	1	1,5 x D	0,3 x D	0,3 x D	50	–	90	fz	0,061	0,070	0,087	0,101	0,114
	2	1,5 x D	0,3 x D	0,3 x D	25	–	40	fz	0,032	0,037	0,046	0,054	0,061
	3	1,5 x D	0,5 x D	1 x D	60	–	80	fz	0,048	0,056	0,070	0,081	0,091
	4	1,5 x D	0,5 x D	1 x D	50	–	60	fz	0,045	0,052	0,064	0,074	0,084
H	1	1,5 x D	0,5 x D	0,75 x D	80	–	140	fz	0,054	0,062	0,077	0,088	0,098

NOTE: Lower value of cutting speed is used for high stock removal applications or for higher hardness (machinability) within group.

Higher value of cutting speed is used for finishing applications or for lower hardness (machinability) within group.

Above parameters are based on ideal conditions. For smaller taper machining centres, please adjust parameters accordingly on >12mm diameters.

■ Series 577E 57NE • Trochoidal Milling/Peel Milling

ae/D	Full Slot	50% ae	40% ae	30% ae	20% ae	10% ae	5% ae	4% ae	2% ae
Speed factors vc	0.9	1	1.1	1.2	1.3	1.4	2.5	3	4
Feed factors fz	0.8	1	1	1.1	1.4	2	2.5	3	4.4
phi [°]	180	90	78.46	66.42	53.13	36.87	25.84	23.07	16.26

Material Group	Cutting Speed – vc m/min	D	4	6	8	10	12	16	20	25		
P	1	vc max [m/min]	vf	20610	21591	22082	21199	20364	18586	16782	14604	mm/min
		600	n	47746	31831	23873	19099	15915	11937	9549	7639	min ⁻¹
	2	vc max [m/min]	vf	19579	20512	20978	20139	19346	17656	15943	13873	mm/min
		570	n	45359	30239	22680	18144	15120	11340	9072	7257	min ⁻¹
	3	vc max [m/min]	vf	14585	15280	15627	15002	14412	13153	11877	10335	mm/min
		480	n	38197	25465	19099	15279	12732	9549	7639	6112	min ⁻¹
	4	vc max [m/min]	vf	11890	12456	12740	12230	11749	10722	9682	8425	mm/min
		450	n	35810	23873	17905	14324	11937	8952	7162	5730	min ⁻¹
	5	vc max [m/min]	vf	7134	7474	7644	7338	7049	6433	5809	5055	mm/min
		300	n	23873	15915	11937	9549	7958	5968	4775	3820	min ⁻¹
	6	vc max [m/min]	vf	4459	4671	4777	4586	4406	4021	3631	3159	mm/min
		225	n	17905	11937	8952	7162	5968	4476	3581	2865	min ⁻¹
M	1	vc max [m/min]	vf	10483	10982	11232	10783	10358	9454	8536	7428	mm/min
		345	n	27454	18303	13727	10982	9151	6864	5491	4393	min ⁻¹
	2	vc max [m/min]	vf	5707	5979	6115	5870	5639	5147	4647	4044	mm/min
		240	n	19099	12732	9549	7639	6366	4775	3820	3056	min ⁻¹
	3	vc max [m/min]	vf	4162	4360	4459	4280	4112	3753	3389	2949	mm/min
		210	n	16711	11141	8356	6685	5570	4178	3342	2674	min ⁻¹
K	1	vc max [m/min]	vf	15457	16193	16561	15899	15273	13939	12587	10953	mm/min
		450	n	35810	23873	17905	14324	11937	8952	7162	5730	min ⁻¹
	2	vc max [m/min]	vf	11851	12415	12697	12189	11710	10687	9650	8397	mm/min
		390	n	31035	20690	15518	12414	10345	7759	6207	4966	min ⁻¹
	3	vc max [m/min]	vf	9274	9716	9937	9539	9164	8364	7552	6572	mm/min
		390	n	31035	20690	15518	12414	10345	7759	6207	4966	min ⁻¹
S	1	vc max [m/min]	vf	8204	8595	8790	8439	8107	7399	6681	5813	mm/min
		270	n	21486	14324	10743	8594	7162	5371	4297	3438	min ⁻¹
	2	vc max [m/min]	vf	1902	1993	2038	1957	1880	1716	1549	1348	mm/min
		120	n	9549	6366	4775	3820	3183	2387	1910	1528	min ⁻¹
	3	vc max [m/min]	vf	5707	5979	6115	5870	5639	5147	4647	4044	mm/min
		240	n	19099	12732	9549	7639	6366	4775	3820	3056	min ⁻¹
	4	vc max [m/min]	vf	3805	3986	4077	3914	3760	3431	3098	2696	mm/min
		180	n	14324	9549	7162	5730	4775	3581	2865	2292	min ⁻¹
H	1	vc max [m/min]	vf	11098	11626	11890	11415	10965	10008	9037	7863	mm/min
		420	n	33423	22282	16711	13369	11141	8356	6685	5348	min ⁻¹

NOTE: For all other combinations of width and depth of cut, feed and speed must be adapted.
Cutting data, which are shown in this catalogue, are applicable under optimum conditions and chip evacuation.

Recommended ae: 0,04 x D, phi~23°, ap = ap max

Speed and feed: 4% ae

- Unequal flute spacing.
- Non-centre cutting.
- For finishing and semi-finishing applications.
- Standard items listed. Additional styles and coatings made to order.

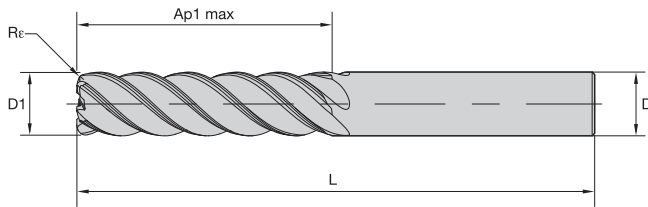
End Mill Tolerances

D1	tolerance e8	D	tolerance h6 + / -
≤ 3	-0,014/-0,028	≤ 3	0/0,006
> 3-6	-0,020/-0,038	> 3-6	0/0,008
> 6-10	-0,025/-0,047	> 6-10	0/0,009
> 10-18	-0,032/-0,059	> 10-18	0/0,011
> 18-30	-0,040/-0,073	> 18-30	0/0,013

	P						M			K			S				H				
	1	2	3	4	5	6	1	2	3	1	2	3	1	2	3	4	1				
ALTIN	●	●	●	●	●	●	●	●	●	○	○	○	○	○	○	○	○	●	●	●	●

P – Steels K – Cast Iron S – High-Temp Alloys
 M – Stainless Steels N – Non-Ferrous H – Hard Materials

For material descriptions, see page 85.

For application data, see page 47.

Series 5718 • VariMill II Long • 4 x D Length of Cut

ALTIN-MT	D1	D	length of cut Ap1 max	length L	Re
571806002MT	6,0	6	24,00	76	—
571806012MT	6,0	6	24,00	76	0,50
571806022MT	6,0	6	24,00	76	1,00
571808003MT	8,0	8	32,00	76	—
571808013MT	8,0	8	32,00	76	0,50
571808023MT	8,0	8	32,00	76	1,00
571810004MT	10,0	10	40,00	100	—
571810014MT	10,0	10	40,00	100	0,50
571810034MT	10,0	10	40,00	100	2,00
571810044MT	10,0	10	40,00	100	2,50
571812005MT	12,0	12	48,00	125	—
571812025MT	12,0	12	48,00	125	1,00
571812035MT	12,0	12	48,00	125	2,00
571812045MT	12,0	12	48,00	125	2,50
571814014MT	14,0	14	56,00	120	—
571814024MT	14,0	14	56,00	120	1,00
571814034MT	14,0	14	56,00	120	2,00
571814044MT	14,0	14	56,00	120	3,00
571814054MT	14,0	14	56,00	120	4,00
571816006MT	16,0	16	64,00	141	—
571816016MT	16,0	16	64,00	141	0,50
571816026MT	16,0	16	64,00	141	1,00
571816036MT	16,0	16	64,00	141	2,00
571816046MT	16,0	16	64,00	141	3,00

(continued)

(Series 5718 • VariMill II Long • 4 x D Length of Cut – continued)

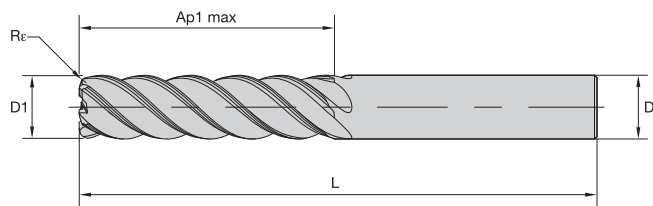

ALTIM	P						M			K			S				H	
	1	2	3	4	5	6	1	2	3	1	2	3	1	2	3	4	1	
ALTIM	●	●	●	●	●	●	●	●	●	○	○	○	○	○	○	○	○	●

P – Steels K – Cast Iron S – High-Temp Alloys
M – Stainless Steels N – Non-Ferrous H – Hard Materials

For material descriptions, see page 85.

For application data, see page 47.

ALTIM-MT	D1	D	length of cut Ap1 max	length L	Re
571816056MT	16,0	16	64,00	141	4,00
571818018MT	18,0	18	72,00	150	—
571818028MT	18,0	18	72,00	150	1,00
571818038MT	18,0	18	72,00	150	2,00
571818048MT	18,0	18	72,00	150	3,00
571818058MT	18,0	18	72,00	150	4,00
571820007MT	20,0	20	80,00	150	—
571820017MT	20,0	20	80,00	150	0,50
571820027MT	20,0	20	80,00	150	1,00
571820037MT	20,0	20	80,00	150	2,00
571820047MT	20,0	20	80,00	150	3,00
571820057MT	20,0	20	80,00	150	4,00
571825008MT	25,0	25	100,00	170	—
571825018MT	25,0	25	100,00	170	0,50
571825028MT	25,0	25	100,00	170	1,00
571825038MT	25,0	25	100,00	170	2,00
571825048MT	25,0	25	100,00	170	3,00
571825058MT	25,0	25	100,00	170	4,00

Series 5718 • VariMill II Long

Material Group															
	Side milling (A)		ALTiN		Recommended feed per tooth (fz=mm/th) for side milling (A).										
	A		Cutting Speed – vc m/min		mm	D1 – Diameter									
	ap	ae	min	max		6,0	8,0	10,0	12,0	14,0	16,0	18,0	20,0	25,0	
P	1	Ap1 max	0,05 x D*	300	400	fz	0,044	0,060	0,060	0,072	0,083	0,092	0,101	0,114	0,124
	2	Ap1 max	0,05 x D*	280	380	fz	0,044	0,060	0,060	0,072	0,083	0,092	0,101	0,114	0,124
	3	Ap1 max	0,05 x D*	240	320	fz	0,036	0,050	0,050	0,061	0,070	0,079	0,087	0,101	0,114
	4	Ap1 max	0,05 x D*	180	300	fz	0,033	0,045	0,045	0,054	0,062	0,070	0,077	0,088	0,098
	5	Ap1 max	0,05 x D*	120	200	fz	0,029	0,040	0,040	0,048	0,056	0,063	0,070	0,081	0,091
	6	Ap1 max	0,05 x D*	100	150	fz	0,025	0,034	0,034	0,040	0,047	0,052	0,057	0,065	0,071
M	1	Ap1 max	0,05 x D*	180	230	fz	0,036	0,050	0,050	0,061	0,070	0,079	0,087	0,101	0,114
	2	Ap1 max	0,05 x D*	120	160	fz	0,029	0,040	0,040	0,048	0,056	0,063	0,070	0,081	0,091
	3	Ap1 max	0,05 x D*	120	140	fz	0,025	0,034	0,034	0,040	0,047	0,052	0,057	0,065	0,071
K	1	Ap1 max	0,05 x D*	240	300	fz	0,044	0,060	0,060	0,072	0,083	0,092	0,101	0,114	0,124
	2	Ap1 max	0,05 x D*	220	260	fz	0,036	0,050	0,050	0,061	0,070	0,079	0,087	0,101	0,114
	3	Ap1 max	0,05 x D*	200	260	fz	0,029	0,040	0,040	0,048	0,056	0,063	0,070	0,081	0,091
S	1	Ap1 max	0,05 x D*	100	180	fz	0,036	0,050	0,050	0,061	0,070	0,079	0,087	0,101	0,114
	2	Ap1 max	0,05 x D*	100	180	fz	0,019	0,026	0,050	0,061	0,070	0,079	0,087	0,101	0,114
	3	Ap1 max	0,05 x D*	50	80	fz	0,029	0,040	0,026	0,032	0,037	0,042	0,046	0,054	0,061
	4	Ap1 max	0,05 x D*	100	120	fz	0,026	0,037	0,037	0,045	0,052	0,058	0,064	0,074	0,084
H	1	Ap1 max	0,05 x D*	140	160	fz	0,033	0,045	0,045	0,054	0,062	0,070	0,077	0,088	0,098

* For the above cutting data, do not exceed an overall ae of 0,8mm.

NOTE: Lower value of cutting speed is used for high stock removal applications or for higher hardness (machinability) within group.

Higher value of cutting speed is used for finishing applications or for lower hardness (machinability) within group.

Above parameters are based on ideal conditions. For smaller taper machining centres, please adjust parameters accordingly on > 0,5mm diameters.

Application Example • VariMill II ER 57NE, 10mm

Smart dynamic machining
Hermle C30 machine
SolidCAM iMachining



1. Titanium Alloy Ti6Al4V
(3.7165)
vc = 122 m/min
h max = 0,075mm
ae max = 0,59mm
ap = 20mm



2. Stainless Steel X6CrNiMoTi
17-12-2 (1.4571)
vc = 161 m/min
h max = 0,061mm
ae max = 0,54mm
ap = 20mm

**All work performed by 1 tool. Tool life over 270m.
This tool ran around a football square made from titanium and stainless steel!**

■ Series 5718 • Trochoidal Milling/Peel Milling

ae/D	Full Slot	50% ae	40% ae	30% ae	20% ae	10% ae	5% ae	4% ae	2% ae
Speed factors vc	0.9	1	1.1	1.2	1.3	1.4	2.5	3	4
Feed factors fz	0.8	1	1	1.1	1.4	2	2.5	3	4.4
phi [°]	180	90	78.46	66.42	53.13	36.87	25.84	23.07	16.26

Material Group	Cutting Speed – vc m/min	D	4	6	8	10	12	16	20	25		
P	1	vc max [m/min]	vf	18434	19312	19751	18961	18215	16623	15011	13062	mm/min
		600	n	47746	31831	23873	19099	15915	11937	9549	7639	min ⁻¹
	2	vc max [m/min]	vf	17512	18346	18763	18013	17304	15792	14260	12409	mm/min
		570	n	45359	30239	22680	18144	15120	11340	9072	7257	min ⁻¹
	3	vc max [m/min]	vf	13046	13667	13977	13418	12890	11764	10623	9244	mm/min
		480	n	38197	25465	19099	15279	12732	9549	7639	6112	min ⁻¹
	4	vc max [m/min]	vf	10635	11141	11395	10939	10508	9590	8660	7536	mm/min
		450	n	35810	23873	17905	14324	11937	8952	7162	5730	min ⁻¹
	5	vc max [m/min]	vf	6381	6685	6837	6563	6305	5754	5196	4521	mm/min
		300	n	23873	15915	11937	9549	7958	5968	4775	3820	min ⁻¹
	6	vc max [m/min]	vf	3988	4178	4273	4102	3941	3596	3247	2826	mm/min
		225	n	17905	11937	8952	7162	5968	4476	3581	2865	min ⁻¹
M	1	vc max [m/min]	vf	9377	9823	10046	9644	9265	8456	7635	6644	mm/min
		345	n	27454	18303	13727	10982	9151	6864	5491	4393	min ⁻¹
	2	vc max [m/min]	vf	5105	5348	5469	5251	5044	4603	4157	3617	mm/min
		240	n	19099	12732	9549	7639	6366	4775	3820	3056	min ⁻¹
	3	vc max [m/min]	vf	3722	3899	3988	3829	3678	3357	3031	2637	mm/min
		210	n	16711	11141	8356	6685	5570	4178	3342	2674	min ⁻¹
K	1	vc max [m/min]	vf	13825	14484	14813	14220	13661	12468	11258	9796	mm/min
		450	n	35810	23873	17905	14324	11937	8952	7162	5730	min ⁻¹
	2	vc max [m/min]	vf	10600	11104	11357	10902	10473	9559	8631	7511	mm/min
		390	n	31035	20690	15518	12414	10345	7759	6207	4966	min ⁻¹
	3	vc max [m/min]	vf	8295	8690	8888	8532	8197	7481	6755	5878	mm/min
		390	n	31035	20690	15518	12414	10345	7759	6207	4966	min ⁻¹
S	1	vc max [m/min]	vf	7338	7688	7862	7548	7251	6617	5975	5200	mm/min
		270	n	21486	14324	10743	8594	7162	5371	4297	3438	min ⁻¹
	2	vc max [m/min]	vf	1702	1783	1823	1750	1681	1534	1386	1206	mm/min
		120	n	9549	6366	4775	3820	3183	2387	1910	1528	min ⁻¹
	3	vc max [m/min]	vf	5105	5348	5469	5251	5044	4603	4157	3617	mm/min
		240	n	19099	12732	9549	7639	6366	4775	3820	3056	min ⁻¹
	4	vc max [m/min]	vf	3403	3565	3646	3500	3363	3069	2771	2411	mm/min
		180	n	14324	9549	7162	5730	4775	3581	2865	2292	min ⁻¹
H	1	vc max [m/min]	vf	9926	10399	10635	10210	9808	8951	8083	7033	mm/min
		420	n	33423	22282	16711	13369	11141	8356	6685	5348	min ⁻¹

NOTE: For all other combinations of width and depth of cut, feed and speed must be adapted.
Cutting data, which are shown in this catalogue, are applicable under optimum conditions and chip evacuation.

Recommended ae: 0,05 x D, phi~28,8°, ap = ap max

Speed and feed: 5% ae

WIN WITH WIDIA™

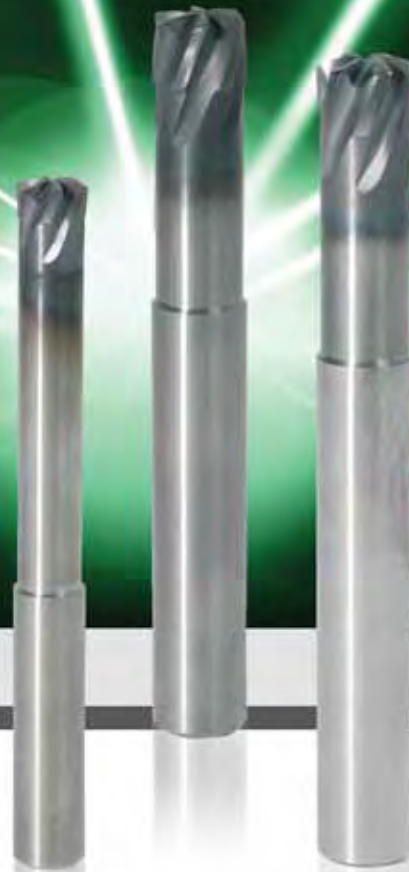

X-Feed™ End Mills for High-Feed Milling

Specifically engineered to machine hardened steel up to 67 HRC at extreme speeds and feeds.

.....

- Unique tool with new 6-flute style for high productivity.
- Necked shanks provide extended reach in deep cavities.
- High-feed rates, up to 0,6mm per tooth on a 20mm tool.
- Machine hardened materials at 2–3x the metal removal rate of competitive end mills.
- Wide range of cutting diameters: down to 6mm for small and medium pocket work.
- Innovative new geometry maximises metal removal rates.
- High metal removal rates lower manufacturing costs.

To learn more about our innovations, contact your local Authorised Distributor or visit www.widia.com.

WIDIA 

High-Performance Solid Carbide End Mills • **HP Rougher**

WIDIA™ high-performance roughing end mills are market-leading, universal, and consistently performing tools for use in a wide range of workpiece materials and types of operations.



HP ROUGHER

- High-performance universal tools for almost all cutting materials.
- Lower cutting forces and spindle power consumption.
- High Metal Removal Rates (MRR) even on unstable machines or with unstable workpiece clamping.
- Roughing profile enables roughing and semi-finishing.

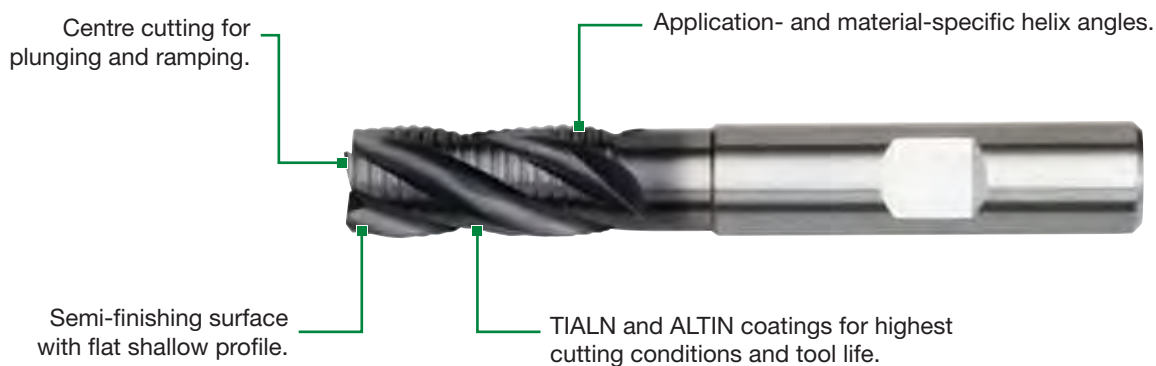

- Centre cutting.
- Flat shallow profile.
- Standard items listed. Additional styles and coatings made to order.

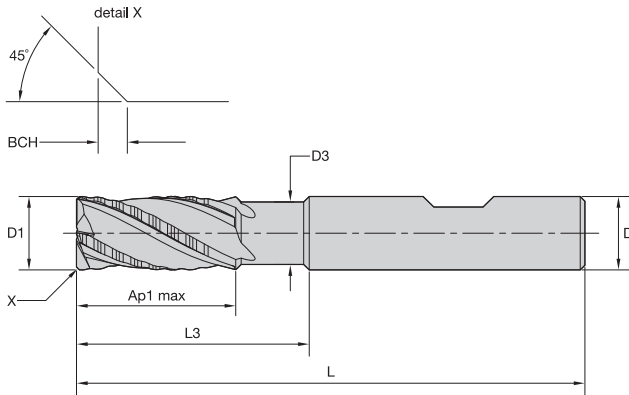
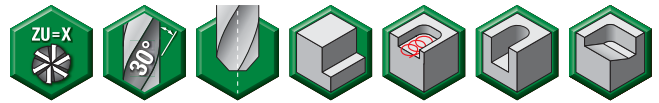

End Mill Tolerances

D1	tolerance d11	D	tolerance h6 + / -
≤ 3	-0,020/-0,080	≤ 3	0/0,006
> 3-6	-0,030/-0,105	> 3-6	0/0,008
> 6-10	-0,040/-0,130	> 6-10	0/0,009
> 10-18	-0,050/-0,160	> 10-18	0/0,011
> 18-30	-0,065/-0,195	> 18-30	0/0,013

	P						M			K			S				H
	1	2	3	4	5	6	1	2	3	1	2	3	1	2	3	4	1
ALTIM	●	●	●	●	○	○	○	○	○	●	●	●	○	○	○	○	○

P – Steels K – Cast Iron S – High-Temp Alloys
M – Stainless Steels N – Non-Ferrous H – Hard Materials

For application data, see page 52.

Series 49N6 • With Neck



ALTIM-MW	D1	D	length of cut Ap1 max	L3	length L	BCH	D3	Z U
49N604002MW	4,0	6	8,00	8,00	57	0,30	—	3
49N605002MW	5,0	6	13,00	13,00	57	0,30	—	3
49N606002MW	6,0	6	13,00	21,00	57	0,30	6	3
49N608003MW	8,0	8	16,00	27,00	63	0,30	8	3
49N610004MW	10,0	10	22,00	32,00	72	0,50	10	4
49N612005MW	12,0	12	26,00	38,00	83	0,50	11	4
49N614014MW	14,0	14	26,00	38,00	83	0,50	13	4
49N616006MW	16,0	16	32,00	44,00	92	0,50	15	4
49N618018MW	18,0	18	32,00	44,00	92	0,50	17	4
49N620007MW	20,0	20	38,00	54,00	104	0,50	19	4
49N625008MW	25,0	25	45,00	65,00	121	0,50	24	5

■ Series 49N6

Material Group																						
	Side Milling (A) and Slotting (B)			ALTIN			Recommended feed per tooth (fz=mm/th) for side milling (A). For slotting (B), reduce fz by 10%.															
	A		B	Cutting Speed – vc m/min			D1 – Diameter															
	ap	ae	ap	min		max	mm	4,0	5,0	6,0	8,0	10,0	12,0	14,0	16,0	18,0	20,0	25,0				
P	1	1.5 x D	0.5 x D	1 x D	150	–	200	fz	0,024	0,031	0,037	0,049	0,059	0,072	0,080	0,087	0,093	0,098	0,105			
	2	1.5 x D	0.5 x D	1 x D	140	–	190	fz	0,024	0,031	0,037	0,049	0,059	0,072	0,080	0,087	0,093	0,098	0,105			
	3	1.5 x D	0.4 x D	0.75 x D	120	–	160	fz	0,020	0,025	0,031	0,041	0,049	0,061	0,068	0,075	0,082	0,087	0,097			
	4	1 x D	0.3 x D	0.5 x D	90	–	150	fz	0,018	0,023	0,028	0,037	0,044	0,054	0,060	0,066	0,072	0,076	0,083			
	5	1.5 x D	0.4 x D	0.75 x D	60	–	100	fz	0,016	0,021	0,025	0,033	0,039	0,049	0,055	0,060	0,065	0,070	0,077			
M	1	1 x D	0.4 x D	0.75 x D	80	–	100	fz	0,020	0,025	0,031	0,041	0,049	0,061	0,068	0,075	0,082	0,087	0,097			
	2	1 x D	0.4 x D	0.75 x D	60	–	80	fz	0,016	0,021	0,025	0,033	0,039	0,049	0,055	0,060	0,065	0,070	0,077			
	3	1 x D	0.4 x D	0.75 x D	60	–	80	fz	0,014	0,017	0,021	0,026	0,032	0,039	0,044	0,048	0,052	0,056	0,060			
K	1	1.5 x D	0.5 x D	1 x D	120	–	160	fz	0,024	0,031	0,037	0,049	0,059	0,072	0,080	0,087	0,093	0,098	0,105			
	2	1.5 x D	0.4 x D	1 x D	110	–	140	fz	0,020	0,025	0,031	0,041	0,049	0,061	0,068	0,075	0,082	0,087	0,097			
S	1	1.5 x D	0.4 x D	0.75 x D	50	–	90	fz	0,020	0,025	0,031	0,041	0,049	0,061	0,068	0,075	0,082	0,087	0,097			
	3	1.5 x D	0.4 x D	0.75 x D	50	–	80	fz	0,016	0,021	0,025	0,033	0,039	0,049	0,055	0,060	0,065	0,070	0,077			
H	1	1.0 x D	0.3 x D	0.5 x D	80	–	140	fz	0,018	0,023	0,028	0,037	0,044	0,054	0,060	0,066	0,072	0,076	0,083			

NOTE: Lower value of cutting speed is used for high stock removal applications or for higher hardness (machinability) within group.
Higher value of cutting speed is used for finishing applications or for lower hardness (machinability) within group.
Above parameters are based on ideal conditions. For smaller taper machining centres, please adjust parameters accordingly on >12mm diameters.

Complete Solid Carbide End Mill Portfolio Can Be Found in:



WIDIA-Hanita™/WIDIA-Rubig™ Solid End Mills & Holemaking catalogue (A-09-02077)

WIDIA™ Advances 2014 catalogue (A-13-03144)

Available at www.widia.com or your local distribution partner.

■ Series 49N6 • Trochoidal Milling/Peel Milling

ae/D	Full Slot	50% ae	40% ae	30% ae	20% ae	10% ae	5% ae	4% ae	2% ae
Speed factors vc	0.9	1	1.1	1.2	1.3	1.4	2.5	3	4
Feed factors fz	0.8	1	1	1.1	1.4	2	2.5	3	4.4
phi [°]	180	90	78.46	66.42	53.13	36.87	25.84	23.07	16.26

Material Group	Cutting Speed – vc m/min	D	4	6	8	10	12	16	20	25		
P	1	vc max [m/min]	vf	13190	13818	14132	13567	13033	11895	10741	9346	mm/min
		600	n	47746	31831	23873	19099	15915	11937	9549	7639	min ⁻¹
	2	vc max [m/min]	vf	12531	13127	13426	12889	12382	11300	10204	8879	mm/min
		570	n	45359	30239	22680	18144	15120	11340	9072	7257	min ⁻¹
	3	vc max [m/min]	vf	9335	9779	10001	9601	9224	8418	7601	6614	mm/min
		480	n	38197	25465	19099	15279	12732	9549	7639	6112	min ⁻¹
	4	vc max [m/min]	vf	7610	7972	8153	7827	7519	6862	6197	5392	mm/min
		450	n	35810	23873	17905	14324	11937	8952	7162	5730	min ⁻¹
	5	vc max [m/min]	vf	4566	4783	4892	4696	4512	4117	3718	3235	mm/min
		300	n	23873	15915	11937	9549	7958	5968	4775	3820	min ⁻¹
	6	vc max [m/min]	vf	2854	2990	3057	2935	2820	2573	2324	2022	mm/min
		225	n	17905	11937	8952	7162	5968	4476	3581	2865	min ⁻¹
M	1	vc max [m/min]	vf	6709	7029	7189	6901	6629	6050	5463	4754	mm/min
		345	n	27454	18303	13727	10982	9151	6864	5491	4393	min ⁻¹
	2	vc max [m/min]	vf	3653	3827	3914	3757	3609	3294	2974	2588	mm/min
		240	n	19099	12732	9549	7639	6366	4775	3820	3056	min ⁻¹
	3	vc max [m/min]	vf	2663	2790	2854	2740	2632	2402	2169	1887	mm/min
		210	n	16711	11141	8356	6685	5570	4178	3342	2674	min ⁻¹
K	1	vc max [m/min]	vf	9893	10364	10599	10175	9775	8921	8055	7010	mm/min
		450	n	35810	23873	17905	14324	11937	8952	7162	5730	min ⁻¹
	2	vc max [m/min]	vf	7584	7946	8126	7801	7494	6840	6176	5374	mm/min
		390	n	31035	20690	15518	12414	10345	7759	6207	4966	min ⁻¹
	3	vc max [m/min]	vf	5936	6218	6360	6105	5865	5353	4833	4206	mm/min
		390	n	31035	20690	15518	12414	10345	7759	6207	4966	min ⁻¹
S	1	vc max [m/min]	vf	5251	5501	5626	5401	5188	4735	4276	3721	mm/min
		270	n	21486	14324	10743	8594	7162	5371	4297	3438	min ⁻¹
	2	vc max [m/min]	vf	1218	1276	1305	1252	1203	1098	991	863	mm/min
		120	n	9549	6366	4775	3820	3183	2387	1910	1528	min ⁻¹
	3	vc max [m/min]	vf	3653	3827	3914	3757	3609	3294	2974	2588	mm/min
		240	n	19099	12732	9549	7639	6366	4775	3820	3056	min ⁻¹
	4	vc max [m/min]	vf	2435	2551	2609	2505	2406	2196	1983	1725	mm/min
		180	n	14324	9549	7162	5730	4775	3581	2865	2292	min ⁻¹
H	1	vc max [m/min]	vf	7102	7441	7610	7305	7018	6405	5783	5033	mm/min
		420	n	33423	22282	16711	13369	11141	8356	6685	5348	min ⁻¹

NOTE: For all other combinations of width and depth of cut, feed and speed must be adapted.
Cutting data, which are shown in this catalogue, are applicable under optimum conditions and chip evacuation.

Recommended ae: 0,04 x D, phi~23°, ap = ap max

Speed and feed: 4% ae

High-Performance Solid Carbide End Mills • **SAFE-λOCK™**

In High-Performance Cutting (HPC), slow microcreeping can cause the cutting tool to be pulled out of the chuck, turning high-quality workpieces to scrap.

Be on the Safe Side with SAFE-λOCK™ in High-Performance Cutting (HPC).



- Highly accurate clamping due to positive connection.
- No loss of accuracy.
- No pullout or spinning of the tool.
- No damage to the workpiece or machine.
- Groove on tool shank is directed so the tool will be pulled into the chuck (depending on direction of rotation).



Order Information

WIDIA™ high-performance end mills with a shank diameter of 12mm (1/2") and larger are available with **SAFE-λOCK™** technology, as a special tool, upon request. Please contact your local customer service location to receive a quote.

Features

- Form-closed clamping.
- High accuracy clamping.
- Helical grooves.

Functions

- No pullout.
- Excellent runout.
- Adjustable clamping length.

Benefits

- Reduce scrap rate.
- Higher tool life.
- No need to change NC programme after regrinding.



Example for Highest Metal Removal Rates



The VariMill II™ ER proprietary design with unequal flute spacing and unique core geometry for chatter-free machining enables slotting operations in titanium up to 1 x D.



SAFE-λOCK

The safety belt for high-performance solid carbide end mills provides a form-closed clamping with high accuracy and helical grooves for length adjustment.

- **SAFE-LOCK™** innovative and unique non-slip system.
- Suitable for carbide and HSS cutting tools.
- Need ≥ 10 kW shrink unit.

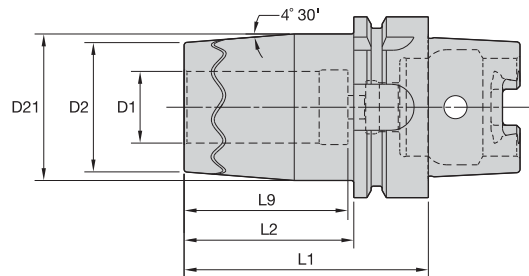

SAFE-LOCK™
by HAIMER

**Cutting Tool Shank Requirements
metric (ISO standard)**

cutting tool shank diameter	tolerance	
3	h4	0,000/-0,003
4	h4	0,000/-0,004
5	h5	0,000/-0,005
6	h6	0,000/-0,008
8 & 10	h6	0,000/-0,009
12, 14, 16, & 18	h6	0,000/-0,011
20 & 25	h6	0,000/-0,013
32	h6	0,000/-0,016

ERICKSON™

■ TT SF MM-HSK Form A

order number	catalogue number	D1	D2	D21	L1	L2	L9	kg
5090218	HSK63ASFTT12070M	12	27	33	70	44	46	0,84
5090219	HSK63ASFTT14075M	14	30	37	75	49	48	0,91
5090220	HSK63ASFTT16075M	16	30	37	75	49	49	0,89
5090221	HSK63ASFTT18075M	18	36	43	75	49	49	1,00
5090222	HSK63ASFTT20075M	20	36	43	75	49	49	0,97
5090223	HSK63ASFTT25085M	25	45	51	85	59	57	1,27
5090224	HSK63ASFTT32085M	32	45	51	85	59	59	1,12

NOTE: Do not overheat. Overheating will destroy the accuracy and functionality of the toolholder.
HSK coolant unit and wrench are available and must be ordered separately;
see the WIDIA™ Tooling Systems catalogue A-09-02122.

- **SAFE-λOCK™** innovative and unique non-slip system.
- Suitable for carbide and HSS cutting tools.
- Need ≥ 10 kW shrink unit.

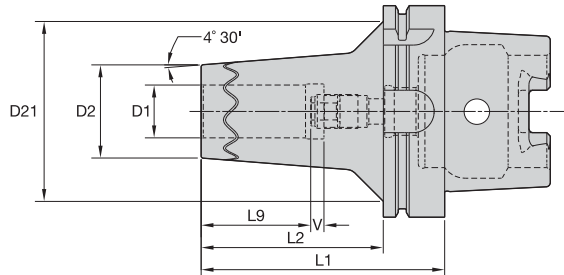

SAFE-λOCK™
by HAIMER

**Cutting Tool Shank Requirements
metric (ISO standard)**

cutting tool shank diameter	tolerance	
6	h6	0,000/-0,008
8 & 10	h6	0,000/-0,009
12, 14, 16, & 18	h6	0,000/-0,011
20 & 25	h6	0,000/-0,013
32	h6	0,000/-0,016

ERICKSON™

■ TT SF MM-HSK Form A

order number	catalogue number	D1	D2	D21	L1	L2	L9	V	kg
5090056	HSK100ASFTT12095M	12	27	73	95	66	37	10	2,45
5090057	HSK100ASFTT14095M	14	33	60	95	66	37	10	2,54
5090058	HSK100ASFTT16100M	16	33	78	100	71	40	10	2,60
5090059	HSK100ASFTT18100M	18	44	76	100	71	40	10	2,98
5090210	HSK100ASFTT20105M	20	44	85	105	76	42	10	3,07
5090211	HSK100ASFTT25115M	25	44	85	115	86	48	10	3,16

*NOTE: Do not overheat. Overheating will destroy the accuracy and functionality of the toolholder.
HSK coolant unit and wrench are available and must be ordered separately;
see the WIDIA™ Tooling Systems catalogue A-09-02122.*

- **SAFE-λOCK™** innovative and unique non-slip system.
- Ultra short and heavy-duty design.
- Suitable for carbide and HSS cutting tools.
- Need ≥ 20 kW shrink unit.

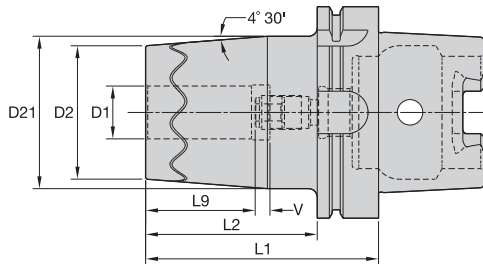

SAFE-λOCK™
by HAIMER

**Cutting Tool Shank Requirements
metric (ISO standard)**

cutting tool shank diameter	tolerance	
6	h6	0,000/-0,008
8 & 10	h6	0,000/-0,009
12, 14, 16, & 18	h6	0,000/-0,011
20 & 25	h6	0,000/-0,013
32	h6	0,000/-0,016

ERICKSON™

■ **TT SF HD MM-HSK Form A**

order number	catalogue number	D1	D2	D21	L1	L2	L9	V	kg
5090212	HSK100ASFHDTT16100M	16	51	62	100	71	40	10	3,27
5090213	HSK100ASFHDTT20100M	20	58	67	100	71	42	10	3,57
5090214	HSK100ASFHDTT25110M	25	63	72	110	81	48	10	4,06
5090215	HSK100ASFHDTT32110M	32	70	78	110	81	52	10	4,37
5090216	HSK100ASFHDTT40140M	40	82	94	140	111	77	10	6,36
5090217	HSK100ASFHDTT50140M	50	82	94	140	111	77	10	5,90

NOTE: Do not overheat. Overheating will destroy the accuracy and functionality of the toolholder.
 HSK coolant unit and wrench are available and must be ordered separately;
 see the WIDIA™ Tooling Systems catalogue A-09-02122.

- **SAFE-λOCK™** innovative and unique non-slip system.
- Suitable for carbide and HSS cutting tools.
- Need ≥ 10 kW shrink unit.

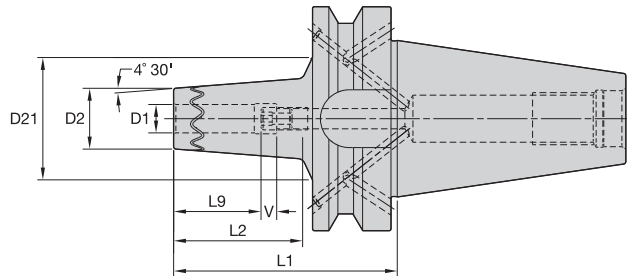

SAFE-λOCK™
by HAIMER

Cutting Tool Shank Requirements
metric (ISO standard)

cutting tool shank diameter	tolerance	
12, 14, 16, & 18	h6	0,000/-0,011
20 & 25	h6	0,000/-0,013
32	h6	0,000/-0,016

ERICKSON™

■ TT SF MM-BT Form B/AD

order number	catalogue number	D1	D2	D21	L1	L2	L9	V	kg
5090264	BT40BSFTT12070M	12	27	33	70	43	37	10	1,14
5090265	BT40BSFTT14075M	14	30	37	75	48	37	10	1,21
5090266	BT40BSFTT16075M	16	30	37	75	48	40	10	1,18
5090267	BT40BSFTT18075M	18	36	43	75	48	40	10	1,29
5090268	BT40BSFTT20075M	20	36	43	75	48	42	10	1,24
5090269	BT40BSFTT25085M	25	46	55	85	58	48	10	1,59
5090270	BT40BSFTT32085M	32	46	55	85	58	48	10	1,43

NOTE: Do not overheat. Overheating will destroy the accuracy and functionality of the toolholder.
For retention knobs, see the WIDIA™ Tooling Systems catalogue A-09-02122.

			40	(2x) SFV40	1,5mm
			50	(2x) SFV50	1,5mm

BT50 Shank Tools

SAFE-λOCK™ Shrink Fit Toolholders



- SAFE-λOCK™ innovative and unique non-slip system.
- Suitable for carbide and HSS cutting tools.
- Need ≥ 10 kW shrink unit.

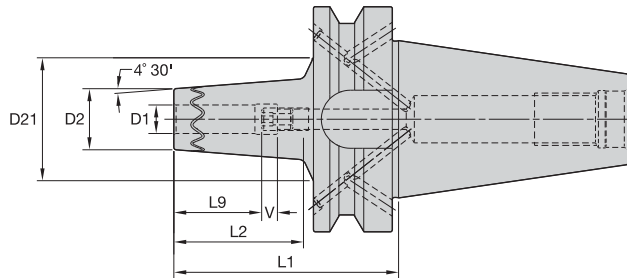

SAFE-λOCK™
by HAIMER

Cutting Tool Shank Requirements
metric (ISO standard)

cutting tool shank diameter	tolerance	
12, 14, 16, & 18	h6	0,000/-0,011
20 & 25	h6	0,000/-0,013

ERICKSON™

■ TT SF HPV MM-BT Form B/AD

order number	catalogue number	D1	D2	D21	L1	L2	L9	V	kg
5090277	BT50BSFTT12100M	12	27	55	100	62	37	10	3,98
5090278	BT50BSFTT14100M	14	33	43	100	62	37	10	4,11
5090279	BT50BSFTT16100M	16	33	43	100	62	40	10	4,08
5090280	BT50BSFTT18100M	18	45	54	100	62	40	10	4,44
5090281	BT50BSFTT20100M	20	45	54	100	62	42	10	4,39
5090282	BT50BSFTT25100M	25	45	54	100	62	48	10	4,29

NOTE: Do not overheat. Overheating will destroy the accuracy and functionality of the toolholder.
HSK coolant unit and wrench are available and must be ordered separately;
see the WIDIA™ Tooling Systems catalogue A-09-02122.

			40	(2x) SFV40	1,5mm
			50	(2x) SFV50	1,5mm

- SAFE-λOCK™ innovative and unique non-slip system.
- Suitable for carbide and HSS cutting tools.
- Need ≥ 10 kW shrink unit.

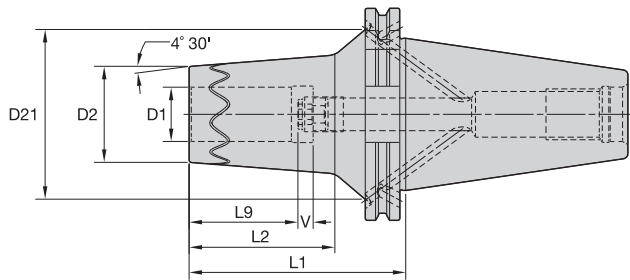

SAFE-λOCK™
by HAIMER

Cutting Tool Shank Requirements
metric (ISO standard)

cutting tool shank diameter	tolerance	
12, 14, 16, & 18	h6	0,000/-0,011
20 & 25	h6	0,000/-0,013
32	h6	0,000/-0,016

ERICKSON

■ TT SF HPV MM-DV Form B/AD

order number	catalogue number	D1	D2	D21	L1	L2	L9	V	kg
5129969	DV40BSFTT12065M	12	27	34	65	46	37	10	1,00
5129970	DV40BSFTT14065M	14	30	37	65	46	37	10	1,04
5090239	DV40BSFTT16065M	16	30	37	65	46	40	10	1,01
5090260	DV40BSFTT18065M	18	36	43	65	46	40	10	1,10
5090261	DV40BSFTT20065M	20	36	43	65	46	42	10	1,07
5090262	DV40BSFTT25075M	25	46	52	75	56	48	10	1,35
5090263	DV40BSFTT32080M	32	46	53	80	61	48	10	1,27

NOTE: Do not overheat. Overheating will destroy the accuracy and functionality of the toolholder.
HSK coolant unit and wrench are available and must be ordered separately;
see the WIDIA™ Tooling Systems catalogue A-09-02122.

			40	(2x) SFV40	1,5mm
			50	(2x) SFV50	1,5mm

- SAFE-λOCK™ innovative and unique non-slip system.
- Suitable for carbide and HSS cutting tools.
- Need ≥ 10 kW shrink unit.

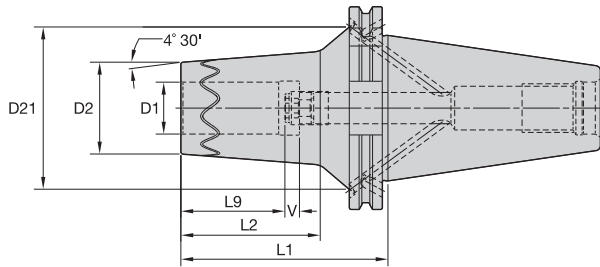

SAFE-λOCK™
by HAIMER

Cutting Tool Shank Requirements
metric (ISO standard)

cutting tool shank diameter	tolerance	
12, 14, 16, & 18	h6	0,000/-0,011
20 & 25	h6	0,000/-0,013

ERICKSON™

■ TT SF HPV MM-DV Form B/AD

order number	catalogue number	D1	D2	D21	L1	L2	L9	V	kg
5090271	DV50BSFTT12080M	12	27	55	80	61	37	10	2,97
5090272	DV50BSFTT14080M	14	33	43	80	61	37	10	3,10
5090273	DV50BSFTT16080M	16	33	43	80	61	40	10	3,06
5090274	DV50BSFTT18080M	18	45	54	80	61	40	10	3,41
5090275	DV50BSFTT20080M	20	45	54	80	61	42	10	3,37
5090276	DV50BSFTT25100M	25	44	78	100	81	48	10	3,72

NOTE: Do not overheat. Overheating will destroy the accuracy and functionality of the toolholder.
HSK coolant unit and wrench are available and must be ordered separately;
see the WIDIA™ Tooling Systems catalogue A-09-02122.

			40	(2x) SFV40	1,5mm
			50	(2x) SFV50	1,5mm

TOOLING SYSTEMS



ERICKSON™ Toolholders

WIDIA™ proudly offers premium quality ERICKSON toolholder products, so you can be sure that you're buying the best the industry has to offer. The entire portfolio — including steep taper, HSK, straight shank extensions, collets, sleeves, and accompanying products — offers high productivity, increased accuracy, and application flexibility.

Designed for both manual and automatic tool changing, ERICKSON interfaces are ideally suited for most machine tools and feature a compact and rigid construction guaranteed to handle high torque and deliver optimal metal removal rates.

To learn more about our innovations, contact your local Authorised Distributor or visit www.widia.com.

ERICKSON™

HydroForce™ HT Hydraulic Chuck High Torque

- First choice solution for rotating applications.
- HydroForce HT gives you an unparalleled combination of accuracy and clamping force.
- HydroForce HT requires only two clamping sizes for all of your tooling applications.

HydroForce

Compact and Stable Design

- Shorter projection length and thicker front wall cross section result in higher rigidity. This allows higher cutting parameters and better surface quality.

Advanced Hydraulic Clamping

- Three times better clamping force than regular hydraulic chucks, runout of 3 microns at 2.5 times diameter overhang vibration dampening. This results in up to 50% longer tool life and improved workpiece surface quality.

Balance Quality at G2.5 at 25.000 RPM

- Lower vibration, particularly at high speeds. This results in higher productivity.

Easy Side Access for Clamping/Unclamping

- Mechanical stop for clamping and 10mm (3/8") length adjustment. This results in reliable, consistent clamping and no over torque. No torque wrench required.

Focused and Flexible Product Offering

- Allows direct clamping for 20mm and 32mm (3/4" and 1-1/4"). Reducer sleeves available for all combinations metric/inch, which results in reduced toolholder inventory, maximum flexibility, and minimum cost.

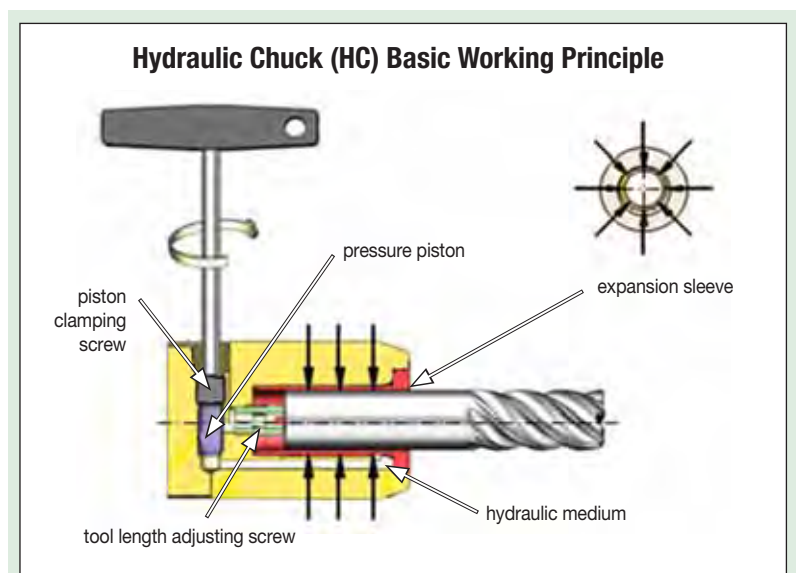



HydroForce™ Advanced Features

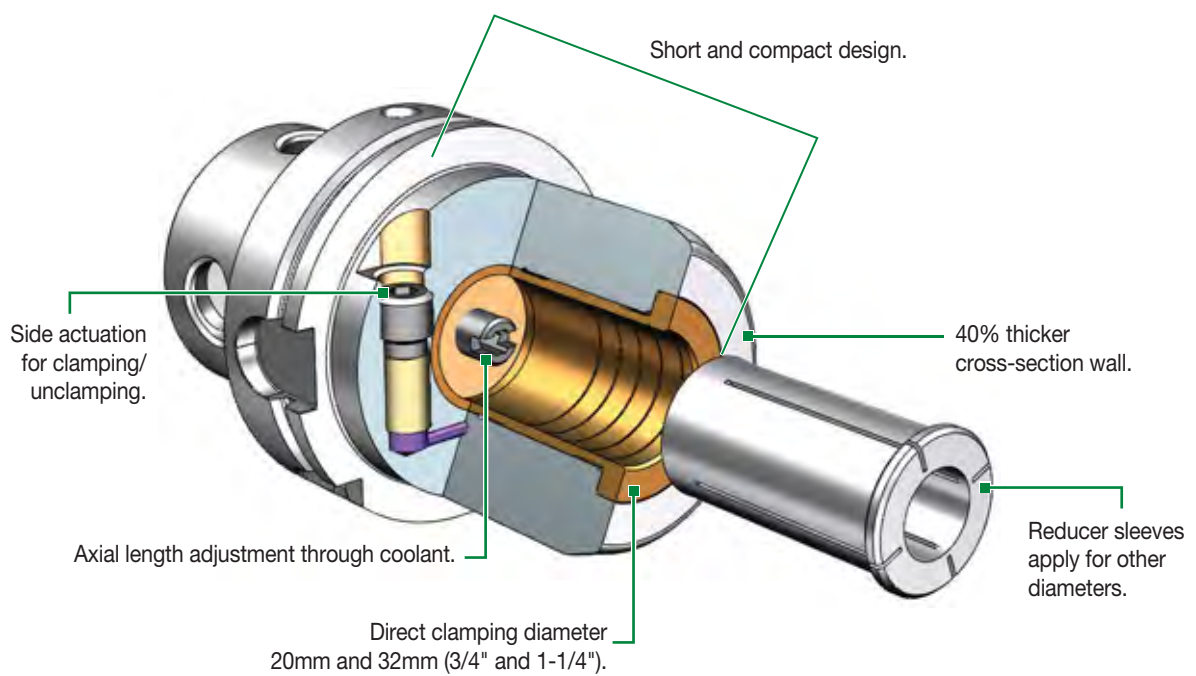

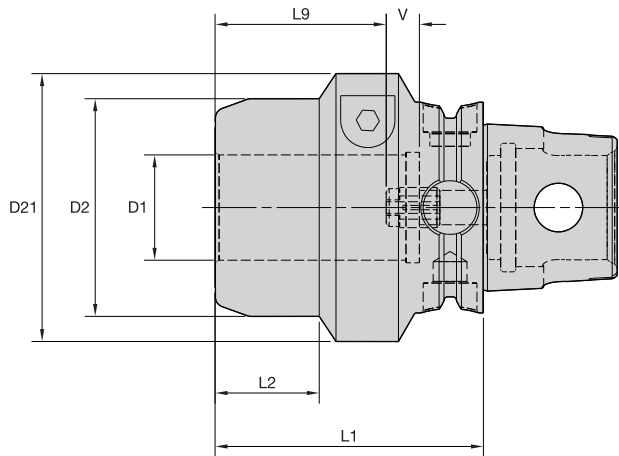

**Cutting Tool Shank Requirements
metric (ISO standard)**

cutting tool shank diameter	tolerance	
6	h6	0,000/-0,008
8 & 10	h6	0,000/-0,009
12, 14, 16, & 18	h6	0,000/-0,011
20	h6	0,000/-0,013

■ **HCTHT • Metric • KM63TS**

order number	catalogue number	D1	D2	D21	L1	L2	L9	V	wrench size actuation screw	wrench size stop screw	kg
5520979	KM63TSHCTHT32080M	32	65,0	80	80	31	51	10	6 mm	6 mm	2,00

NOTE: Do not overtorque actuation screw. Tighten by hand until stop is felt.
 Hydraulic chuck technical section, see pages K60–K63 of the WIDIA™ Tooling Systems catalogue A-09-02122.
 Supplied with stop screw.
 Actuation wrench must be ordered separately.
 For diameter D1 32mm (1-1/4"), use an L-shape Allen wrench with side length of approximately 200mm.

WIN WITH WIDIA™



AluSurf™ Carbide End Mills for High Metal Removal Rates and Superior Surface Finishes

Designed to significantly reduce machining time in aluminium!

.....

- Use only one tool for roughing and finishing operations.
- Slotting is effective up to full, 1 x D axial depth; side milling (profiling) is effective up to 0,5 x D, radial by 1,5 x D axial depth.
- Three-flute series uses unequal flute spacing for chatter-free performance.
- Effective in a full range of machine speeds.
- Multiple corner radii and extended neck configurations are available as standard.

To learn more about our innovations, contact your local Authorised Distributor or visit www.widia.com.

WIDIA 

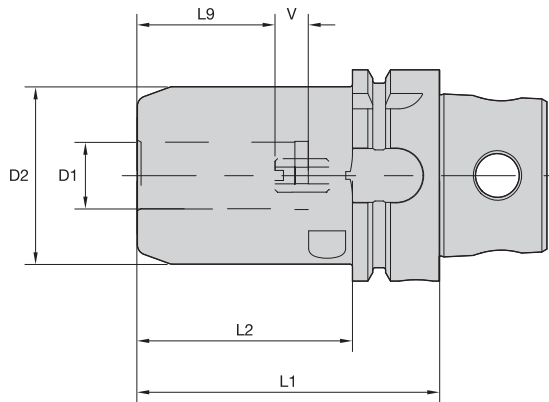

L9: minimum clamping length
V: maximum adjusting length



**Cutting Tool Shank Requirements
metric (ISO standard)**

cutting tool shank diameter	tolerance	
6	h6	0,000/-0,008
8 & 10	h6	0,000/-0,009
12, 14, 16, & 18	h6	0,000/-0,011
20	h6	0,000/-0,013



■ HCTHT • Metric • KM4X™

order number	catalogue number	D1	D2	L1	L2	L9	V	wrench size actuation screw	wrench size stop screw	kg
5520990	KM4X63HCTHT20090M	20	52,5	90	64	41	10	5 mm	5 mm	1,63

NOTE: Do not overtorque actuation screw. Tighten by hand until stop is felt.
Hydraulic chuck technical section, see pages K60–K63 of the WIDIA™ Tooling Systems catalogue A-09-02122.
Supplied with stop screw.
Actuation wrench must be ordered separately.
KM4X63 coolant unit and wrench are available and must be ordered separately; order number 5572428.

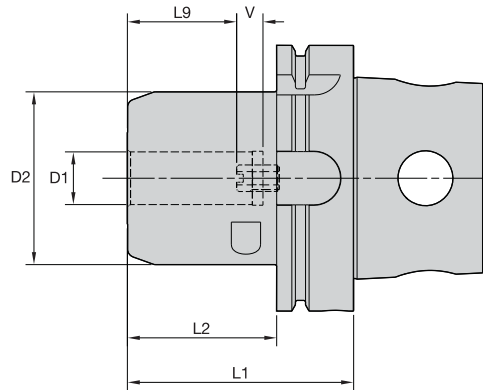

**Cutting Tool Shank Requirements
metric (ISO standard)**

cutting tool shank diameter	tolerance	
6	h6	0,000/-0,008
8 & 10	h6	0,000/-0,009
12, 14, 16, & 18	h6	0,000/-0,011
20	h6	0,000/-0,013



■ HCTHT • Metric • KM4X™

order number	catalogue number	D1	D2	L1	L2	L9	V	wrench size actuation screw	wrench size stop screw	kg
5520991	KM4X100HCTHT20085M	20	65,0	85	56	41	10	5 mm	5 mm	3,53
5520992	KM4X100HCTHT32095M	32	80,0	95	66	51	10	6 mm	6 mm	4,37

NOTE: Do not overtorque actuation screw. Tighten by hand until stop is felt.
Hydraulic chuck technical section, see pages K60–K63 of the WIDIA™ Tooling Systems catalogue A-09-02122.
Supplied with stop screw.
Actuation wrench must be ordered separately.
KM4X63 coolant unit and wrench are available and must be ordered separately; order number 5572428.

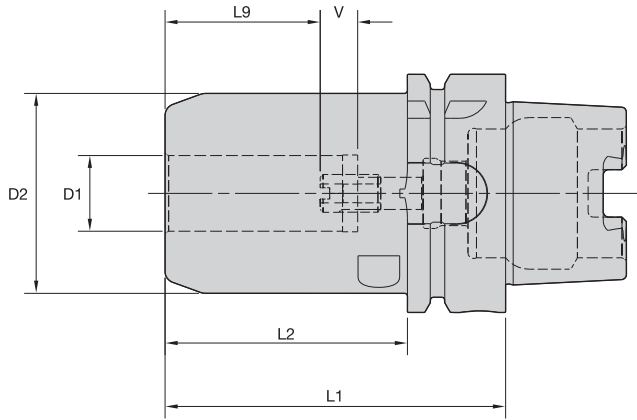

L9: minimum clamping length
V: maximum adjusting length



Cutting Tool Shank Requirements
metric (ISO standard)

cutting tool shank diameter	tolerance	
6	h6	0,000/-0,008
8 & 10	h6	0,000/-0,009
12, 14, 16, & 18	h6	0,000/-0,011
20	h6	0,000/-0,013

ERICKSON™

■ HCTHT • Metric • HSK Form A

order number	catalogue number	D1	D2	L1	L2	L9	V	wrench size actuation screw	wrench size stop screw	kg
5520975	HSK63AHCTHT20090M	20	52,5	90	64	41	10	5 mm	5 mm	1,54

NOTE: Do not overtorque actuation screw. Tighten by hand until stop is felt.
Hydraulic chuck technical section, see pages K60–K63 of the WIDIA™ Tooling Systems catalogue A-09-02122.
Wrenches must be ordered separately.
Supplied with stop screw.
Actuation wrench must be ordered separately.
HSK coolant unit and wrench are available and must be ordered separately;
see page J32 of the WIDIA Tooling Systems catalogue A-09-02122.

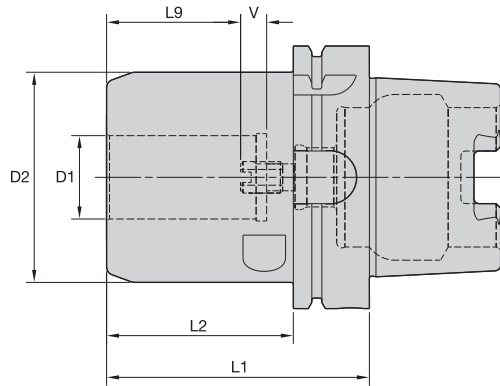

**Cutting Tool Shank Requirements
metric (ISO standard)**

cutting tool shank diameter	tolerance	
6	h6	0,000/-0,008
8 & 10	h6	0,000/-0,009
12, 14, 16, & 18	h6	0,000/-0,011
20	h6	0,000/-0,013

ERICKSON™

■ HCTHT • Metric • HSK Form A

order number	catalogue number	D1	D2	L1	L2	L9	V	wrench size actuation screw	wrench size stop screw	kg
5520976	HSK100AHCTHT20090M	20	65,0	90	61	41	10	5 mm	5 mm	3,38
5520977	HSK100AHCTHT32100M	32	80,0	100	71	51	10	6 mm	6 mm	4,29

NOTE: Do not overtorque actuation screw. Tighten by hand until stop is felt.
Hydraulic chuck technical section, see pages K60–K63 of the WIDIA™ Tooling Systems catalogue A-09-02122.
Supplied with stop screw.
Actuation wrench must be ordered separately.
HSK coolant unit and wrench are available and must be ordered separately;
see page J32 of the WIDIA Tooling Systems catalogue A-09-02122.
For diameter D1 32mm (1-1/4"), use an L-shape Allen wrench with side length of approximately 200mm.

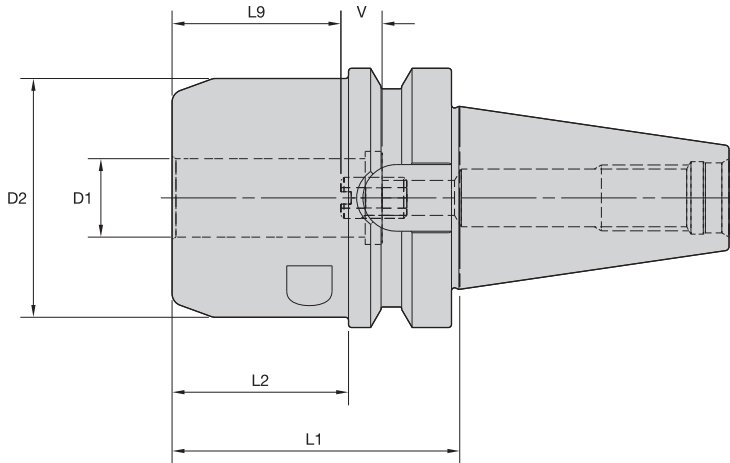

L9: minimum clamping length
V: maximum adjusting length



**Cutting Tool Shank Requirements
metric (ISO standard)**

cutting tool shank diameter	tolerance	
6	h6	0,000/-0,008
8 & 10	h6	0,000/-0,009
12, 14, 16, & 18	h6	0,000/-0,011
20	h6	0,000/-0,013

ERICKSON™

■ HCTHT • Metric • BT40

order number	catalogue number	D1	D2	L1	L2	L9	V	wrench size actuation screw	wrench size stop screw	kg
5520971	BT40HCTHT20070M	20	58	70	43	41	10	5 mm	5 mm	1,67

NOTE: Do not overtorque actuation screw. Tighten by hand until stop is felt.
Hydraulic chuck technical section, see pages K60–K63 of the WIDIA™ Tooling Systems catalogue A-09-02122.
Supplied with stop screw.
Actuation wrench must be ordered separately.
For retention knobs, see pages J33–J38 of the WIDIA Tooling Systems catalogue A-09-02122.

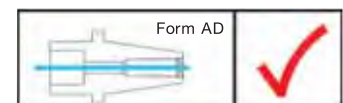

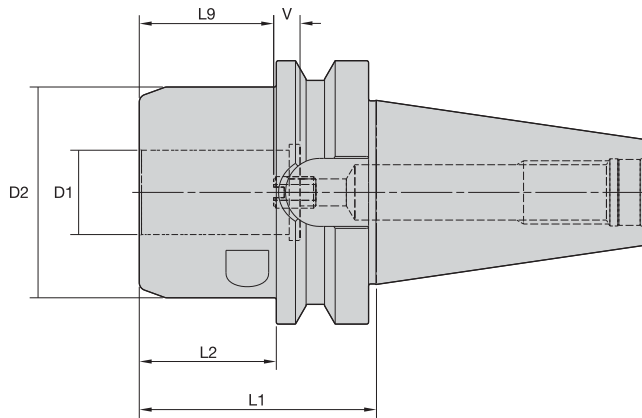

L9: minimum clamping length
V: maximum adjusting length



**Cutting Tool Shank Requirements
metric (ISO standard)**

cutting tool shank diameter	tolerance	
6	h6	0,000/-0,008
8 & 10	h6	0,000/-0,009
12, 14, 16, & 18	h6	0,000/-0,011
20	h6	0,000/-0,013

ERICKSON™

■ HCTHT • Metric • BT50

order number	catalogue number	D1	D2	L1	L2	L9	V	wrench size actuation screw	wrench size stop screw	kg
5520972	BT50HCTHT32090M	32	80	90	52	51	10	6 mm	6 mm	5,09

NOTE: Do not overtorque actuation screw. Tighten by hand until stop is felt.
Hydraulic chuck technical section, see pages K60–K63 of the WIDIA™ Tooling Systems catalogue A-09-02122.
Supplied with stop screw.
Actuation wrench must be ordered separately.
For retention knobs, see pages J33–J38 of the WIDIA Tooling Systems catalogue A-09-02122.
For D1 of 32mm (1,25"), please use 6mm Allen wrench with minimum length of 180mm.

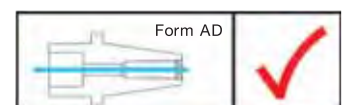

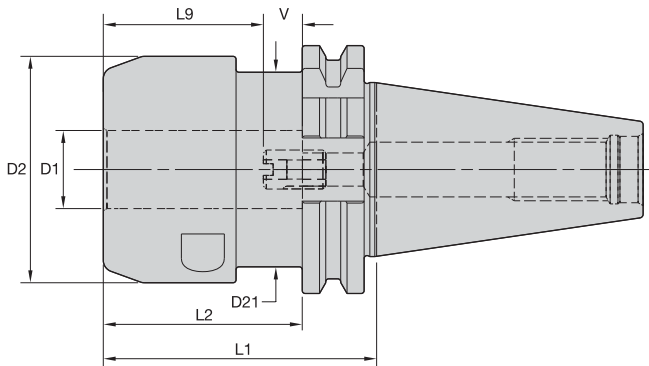

L9: minimum clamping length
V: maximum adjusting length



Cutting Tool Shank Requirements
metric (ISO standard)

cutting tool shank diameter	tolerance	
6	h6	0,000/-0,008
8 & 10	h6	0,000/-0,009
12, 14, 16, & 18	h6	0,000/-0,011
20	h6	0,000/-0,013

ERICKSON™

■ HCTHT • Metric • DV40

order number	catalogue number	D1	D2	L1	L2	L9	V	wrench size actuation screw	wrench size stop screw	kg
5520973	DV40HCTHT20070M	20	58	70	51	41	10	5 mm	5 mm	1,58

NOTE: Do not overtorque actuation screw. Tighten by hand until stop is felt.
Hydraulic chuck technical section, see pages K60–K63 of the WIDIA™ Tooling Systems catalogue A-09-02122.
Supplied with stop screw.
Actuation wrench must be ordered separately.
For retention knobs, see pages J33–J38 of the WIDIA Tooling Systems catalogue A-09-02122.
For diameter D1 32mm (1-1/4"), use an L-shape Allen wrench with side length of approximately 200mm.

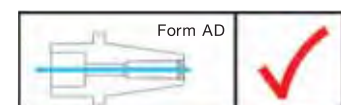

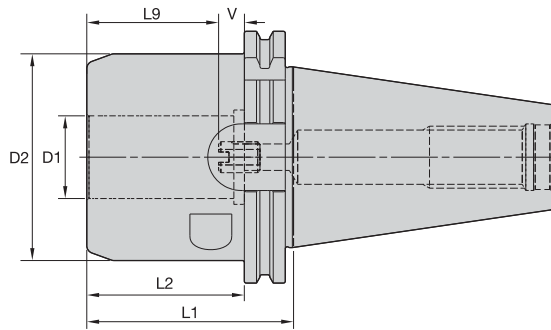

L9: minimum clamping length
V: maximum adjusting length



**Cutting Tool Shank Requirements
metric (ISO standard)**

cutting tool shank diameter	tolerance	
	6	h6
8 & 10	h6	0,000/-0,009
12, 14, 16, & 18	h6	0,000/-0,011
20	h6	0,000/-0,013

ERICKSON™

■ HCTHT • Metric • DV50

order number	catalogue number	D1	D2	L1	L2	L9	V	wrench size actuation screw	wrench size stop screw	kg
5520974	DV50HCTHT32080M	32	80	80	61	51	10	6 mm	6 mm	4,45

NOTE: Do not overtorque actuation screw. Tighten by hand until stop is felt.
Hydraulic chuck technical section, see pages K60–K63 of the WIDIA™ Tooling Systems catalogue A-09-02122.
Supplied with stop screw.
Actuation wrench must be ordered separately.
For retention knobs, see pages J33–J38 of the WIDIA Tooling Systems catalogue A-09-02122.
For diameter D1 32mm (1-1/4"), use an L-shape Allen wrench with side length of approximately 200mm.

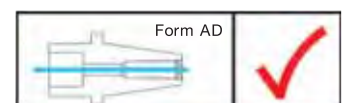

ERICKSON™ HC Hydraulic Chuck Sleeve

ERICKSON Hydraulic Reduction Sleeves are specially designed for high-precision clamping of straight cylindrical cutting tool shanks. The self-sealing design enables efficient use of through-coolant cutting tools when the cutting tool shank completely engages the full gripping length of the sleeve.



HC

- One-piece design with slot configuration to seal coolant.
- Cutting tool must be cylindrical and have a through hole when using coolant.
- Capable of up to 100 bar (1,500 psi) coolant pressure.
- Cutting tool shank requirement tolerance is h6 and $Ra \geq 0,3 \mu\text{m}$ (12 μin) surface finish.
- Maximum collapse is h6.

- One-piece design with slot configuration to seal coolant.
- Cutting tool must be cylindrical and have a through hole when using coolant.
- Sleeve must be inserted completely into the hydraulic chuck until shoulder mates against the hydraulic chuck front face.
- Cutting tools must be in full contact with the sleeve bore length (L1).

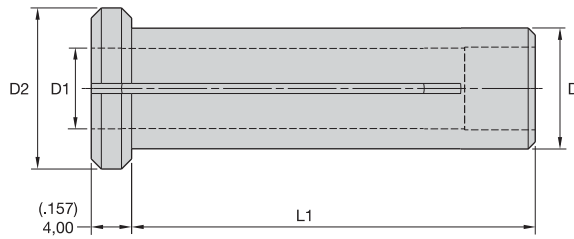

ERICKSON™

■ Metric with Metric Bores

D1	20HC D = 20mm D2 = 25mm L1 = 50mm	32HC D = 32mm D2 = 36mm L1 = 60mm
3,0	20MHC030M	—
4,0	20MHC040M	—
5,0	20MHC050M	—
6,0	20MHC060M	32MHC060M
7,0	20MHC070M	32MHC070M
8,0	20MHC080M	32MHC080M
9,0	20MHC090M	32MHC090M
10,0	20MHC100M	32MHC100M
11,0	20MHC110M	32MHC110M
12,0	20MHC120M	32MHC120M
13,0	20MHC130M	32MHC130M
14,0	20MHC140M	32MHC140M
15,0	20MHC150M	32MHC150M
16,0	20MHC160M	32MHC160M
17,0	—	32MHC170M
18,0	—	32MHC180M
19,0	—	32MHC190M
20,0	—	32MHC200M
22,0	—	32MHC220M
25,0	—	32MHC250M

NOTE: Inserting the cutting tool less than the full gripping length (L1) of the sleeve can permanently damage the sleeve and hydraulic chuck. Full length of the gripping bore needs to be maintained to achieve maximum accuracy, safety, and coolant sealing feature.

■ Tolerances

End Mill Tolerances

D1	tolerance e8	D	tolerance h6 + / -
≤3	-0,014/-0,028	≤3	0/0,006
>3-6	-0,020/-0,038	>3-6	0/0,008
>6-10	-0,025/-0,047	>6-10	0/0,009
>10-18	-0,032/-0,059	>10-18	0/0,011
>18-30	-0,040/-0,073	>18-30	0/0,013

■ Additional Formulas

Symbol Definitions

Legend	
vc	cutting speed
n	revolutions per minute (RPM)
D1	cutter diameter
vf	feed (mm/min)
fz	feed per tooth
Z	number of effective teeth or inserts in cutter
π	3.1416
Ap1	depth of cut
ae	radial width of cut
D	diameter of insert (round inserts)
hm	average chip thickness
h	chip thickness
χr	cutting edge lead angle

■ Calculating Speed and Feed

to find	given	formula
vc	D1 n	$vc = \frac{\pi \times D1 \times n}{1000}$
n	D1 vc	$n = \frac{1000 \times vc}{\pi \times D1}$
vf	fz n Z	$vf = fz \times Z \times n$
fz	Z vf n	$fz = \frac{vf}{Z \times n}$

given	calculated
D1 = 125mm cutter diameter Z = 8 teeth in cutter vc = 200 mm/min fz = 0,2mm	$n = \frac{1000 \times 200}{3.1416 \times 125} = 510 \text{ RPM}$
	$vf = 0,20 \times 8 \times 510 = 816 \text{ mm/min}$

■ **Metal Removal Rate Q**

$$\text{MRR} = \frac{A_{p1} \times a_e \times v_f}{1000}$$

■ **3D Machining**

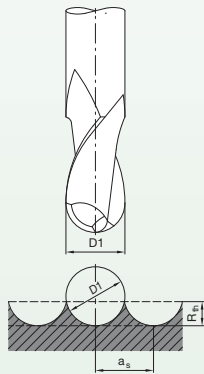

Calculating the theoretical raw depth Rth

$$R_{th} = \frac{D_1}{2} - \frac{\sqrt{D_1^2 - a_s^2}}{4}$$

Calculating the row distance as as

$$a_s = 2\sqrt{R_{th}(D_1 - R_{th})}$$

- D1 = Cutting edge diameter [mm/in]
- Rth = Theoretical raw depth [mm/in]
- as = Row distance

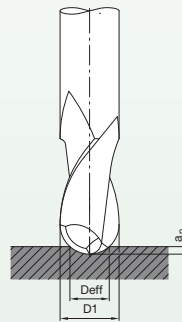

Calculating the effective diameter Deff

$$D_{eff} = 2\sqrt{a_p(D_1 - a_p)}$$

- D1 = Cutting edge diameter [mm/in]
- Deff = Effective diameter [mm/in]
- ap = Axial adjustment depth

Complete Tooling Systems Portfolio Can Be Found in:



WIDIA Tooling Systems
 2012 Catalogue
 (A-09-02122)

Available at www.widia.com or your local distribution partner.

Order Number	Description	Grade	Price (€)	Group Discount	Order Number	Description	Grade	Price (€)	Group Discount
1920424	477704002LT	TIALN-LT	37,20	T3	3592828	477806002MW	ALTIN-MW	40,30	T3
2882431	477704002LW	TIALN-LW	37,95	T3	2545570	477807003MT	ALTIN-MT	49,85	T3
3077746	477704012LT	TIALN-LT	38,90	T3	3592829	477807003MW	ALTIN-MW	50,90	T3
3077757	4777040Z2LT	TIALN-LT	33,80	T3	2545603	477808003MT	ALTIN-MT	49,85	T3
1920427	477705002LT	TIALN-LT	37,20	T3	3592830	477808003MW	ALTIN-MW	50,90	T3
2882432	477705002LW	TIALN-LW	37,95	T3	2545605	477809004MT	ALTIN-MT	72,60	T3
3077745	477705012LT	TIALN-LT	38,90	T3	3592831	477809004MW	ALTIN-MW	74,00	T3
3077756	4777050Z2LT	TIALN-LT	33,80	T3	2601245	477810004MT	ALTIN-MT	72,60	T3
1920430	477706002LT	TIALN-LT	37,20	T3	3592832	477810004MW	ALTIN-MW	74,00	T3
2882983	477706002LW	TIALN-LW	37,95	T3	2601246	477812005MT	ALTIN-MT	101,00	T3
3077744	477706012LT	TIALN-LT	38,90	T3	3592833	477812005MW	ALTIN-MW	103,00	T3
3077755	4777060Z2LT	TIALN-LT	33,80	T3	2601248	477814014MT	ALTIN-MT	139,00	T3
1920431	477707003LT	TIALN-LT	46,90	T3	3592834	477814014MW	ALTIN-MW	142,00	T3
2882984	477707003LW	TIALN-LW	47,85	T3	2601249	477816006MT	ALTIN-MT	160,50	T3
3077736	477707013LT	TIALN-LT	49,05	T3	3592835	477816006MW	ALTIN-MW	163,50	T3
3077754	4777070Z3LT	TIALN-LT	42,65	T3	2601250	477818018MT	ALTIN-MT	209,50	T3
1920432	477708003LT	TIALN-LT	46,90	T3	3592836	477818018MW	ALTIN-MW	213,50	T3
2882985	477708003LW	TIALN-LW	47,85	T3	2601251	477820007MT	ALTIN-MT	234,00	T3
3077742	477708013LT	TIALN-LT	49,05	T3	3592837	477820007MW	ALTIN-MW	238,50	T3
3077753	4777080Z3LT	TIALN-LT	42,65	T3	2601252	477825008MT	ALTIN-MT	347,50	T3
1920433	477709004LT	TIALN-LT	68,30	T3	3592838	477825008MW	ALTIN-MW	354,50	T3
2882986	477709004LW	TIALN-LW	69,70	T3	3641112	471706002LW	TIALN-LW	42,50	T3
3077741	477709014LT	TIALN-LT	71,40	T3	3641113	471708003LW	TIALN-LW	55,20	T3
3077752	4777090Z4LT	TIALN-LT	62,10	T3	3641114	471710004LW	TIALN-LW	77,80	T3
1920434	477710004LT	TIALN-LT	68,30	T3	3641115	471712005LW	TIALN-LW	108,00	T3
2882987	477710004LW	TIALN-LW	69,70	T3	3641116	471716006LW	TIALN-LW	179,50	T3
3077740	477710024LT	TIALN-LT	71,40	T3	3641117	471720007LW	TIALN-LW	292,00	T3
3077751	4777100Z4LT	TIALN-LT	62,10	T3	3641118	472712005LW	TIALN-LW	270,00	SV
3077750	4777110Z5LT	TIALN-LT	86,30	T3	3641119	472716006LW	TIALN-LW	398,00	SV
1920436	477712005LT	TIALN-LT	95,00	T3	3641120	472720007LW	TIALN-LW	594,00	SV
2882988	477712005LW	TIALN-LW	96,90	T3	3462450	47N704002LT	TIALN-LT	46,65	T3
3077739	477712025LT	TIALN-LT	95,00	T3	3462451	47N704012LT	TIALN-LT	46,65	T3
3077749	4777120Z5LT	TIALN-LT	86,30	T3	3462452	47N704012MT	ALTIN-MT	47,45	T3
1920437	477714014LT	TIALN-LT	131,00	T3	3462453	47N704022LT	TIALN-LT	46,65	T3
2882989	477714014LW	TIALN-LW	133,50	T3	3462454	47N705002LT	TIALN-LT	46,65	T3
1920438	477716006LT	TIALN-LT	151,00	T3	3462455	47N705012LT	TIALN-LT	46,65	T3
2202395	477716006LW	TIALN-LW	154,00	T3	3462456	47N705012MT	ALTIN-MT	47,45	T3
3077738	477716026LT	TIALN-LT	157,50	T3	3462457	47N706002LT	TIALN-LT	46,65	T3
3077748	4777160Z6LT	TIALN-LT	137,00	T3	3462458	47N706002MT	ALTIN-MT	47,45	T3
1920439	477718018LT	TIALN-LT	197,00	T3	3462459	47N706012LT	TIALN-LT	46,65	T3
2882990	477718018LW	TIALN-LW	201,00	T3	3462460	47N706012MT	ALTIN-MT	47,45	T3
1920442	477720007LT	TIALN-LT	220,50	T3	3462461	47N706022LT	TIALN-LT	46,65	T3
1972613	477720007LW	TIALN-LW	224,50	T3	3462462	47N708003LT	TIALN-LT	58,90	T3
3077737	477720027LT	TIALN-LT	230,50	T3	3462463	47N708003MT	ALTIN-MT	59,80	T3
3077747	4777200Z7LT	TIALN-LT	200,00	T3	3462464	47N708013LT	TIALN-LT	58,90	T3
1920454	477725008LT	TIALN-LT	327,00	T3	3462465	47N708013MT	ALTIN-MT	59,80	T3
3462447	477725008LW	TIALN-LW	333,50	T3	3462466	47N708023LT	TIALN-LT	58,90	T3
2545563	477804002MT	ALTIN-MT	39,55	T3	3462467	47N708033LT	TIALN-LT	58,90	T3
3592826	477804002MW	ALTIN-MW	40,30	T3	3462468	47N710004LT	TIALN-LT	85,70	T3
2545564	477805002MT	ALTIN-MT	39,55	T3	3462469	47N710004MT	ALTIN-MT	87,10	T3
3592827	477805002MW	ALTIN-MW	40,30	T3	3462470	47N710014LT	TIALN-LT	85,70	T3
2545565	477806002MT	ALTIN-MT	39,55	T3	3462471	47N710014MT	ALTIN-MT	87,10	T3

Prices are valid starting January 1, 2015.

Order Number	Description	Grade	Price (€)	Group Discount	Order Number	Description	Grade	Price (€)	Group Discount
3462472	47N710024LT	TIALN-LT	85,70	T3	3524596	577710004MT	ALTIN-MT	79,60	T3
3462473	47N710034LT	TIALN-LT	85,70	T3	3524617	577710004MW	ALTIN-MW	81,20	T3
3462474	47N710034MT	ALTIN-MT	87,10	T3	3524595	577710014MT	ALTIN-MT	69,30	T3
3462475	47N712005LT	TIALN-LT	119,00	T3	3524598	577712005MT	ALTIN-MT	108,00	T3
3462476	47N712005MT	ALTIN-MT	121,00	T3	3524618	577712005MW	ALTIN-MW	110,00	T3
3462477	47N712015LT	TIALN-LT	119,00	T3	3524597	577712015MT	ALTIN-MT	93,90	T3
3462478	47N712015MT	ALTIN-MT	121,00	T3	3524599	577714004MT	ALTIN-MT	146,00	T3
3462479	47N712025LT	TIALN-LT	119,00	T3	3524619	577714004MW	ALTIN-MW	149,00	T3
3462480	47N712035LT	TIALN-LT	119,00	T3	3717406	577714014MT	ALTIN-MT	127,00	T3
3462481	47N712035MT	ALTIN-MT	121,00	T3	3524601	577716006MT	ALTIN-MT	167,00	T3
3462482	47N712045LT	TIALN-LT	119,00	T3	3524620	577716006MW	ALTIN-MW	170,50	T3
3462483	47N712045MT	ALTIN-MT	121,00	T3	3524600	577716016MT	ALTIN-MT	145,50	T3
3462484	47N716006LT	TIALN-LT	189,50	T3	3524602	577718008MT	ALTIN-MT	215,50	T3
3462485	47N716006MT	ALTIN-MT	192,50	T3	3524621	577718008MW	ALTIN-MW	219,50	T3
3462486	47N716016LT	TIALN-LT	189,50	T3	3524605	577720007MT	ALTIN-MT	240,00	T3
3462487	47N716016MT	ALTIN-MT	192,50	T3	3524622	577720007MW	ALTIN-MW	244,50	T3
3462488	47N716026LT	TIALN-LT	189,50	T3	3524603	577720017MT	ALTIN-MT	208,50	T3
3462489	47N716026MT	ALTIN-MT	192,50	T3	3524606	577725008MT	ALTIN-MT	353,00	T3
3462490	47N720007LT	TIALN-LT	276,50	T3	3524623	577725008MW	ALTIN-MW	360,00	T3
3462491	47N720007MT	ALTIN-MT	281,00	T3	3881109	577C06002MW	ALTIN-MW	48,40	T3
3462492	47N720017LT	TIALN-LT	276,50	T3	3881110	577C08003MW	ALTIN-MW	58,70	T3
3462493	47N720017MT	ALTIN-MT	281,00	T3	3881111	577C10004MW	ALTIN-MW	81,20	T3
3462494	47N720027LT	TIALN-LT	276,50	T3	3881112	577C12005MW	ALTIN-MW	110,00	T3
3462495	47N720027MT	ALTIN-MT	281,00	T3	3881113	577C16006MW	ALTIN-MW	170,50	T3
4067705	47N606002LW	TIALN-LW	51,00	T3	3881114	577C20007MW	ALTIN-MW	244,50	T3
4067706	47N608003LW	TIALN-LW	66,30	T3	3524626	57N806002MT	ALTIN-MT	49,50	T3
4067707	47N610004LW	TIALN-LW	93,40	T3	3524627	57N806022MT	ALTIN-MT	56,90	T3
4067708	47N612005LW	TIALN-LW	130,00	T3	3524667	57N806022MW	ALTIN-MW	58,10	T3
4067709	47N616006LW	TIALN-LW	215,00	T3	3524628	57N806032MT	ALTIN-MT	56,90	T3
4067710	47N620007LW	TIALN-LW	350,50	T3	3524668	57N806032MW	ALTIN-MW	58,10	T3
2605589	47N005002LT	TIALN-LT	48,70	T3	3524669	57N806042MW	ALTIN-MW	58,10	T3
2605590	47N006002LT	TIALN-LT	48,70	T3	3524629	57N808003MT	ALTIN-MT	61,90	T3
2605591	47N008003LT	TIALN-LT	61,40	T3	3524631	57N808023MT	ALTIN-MT	71,20	T3
2605592	47N010004LT	TIALN-LT	89,40	T3	3524670	57N808023MW	ALTIN-MW	72,60	T3
2605593	47N012005LT	TIALN-LT	124,50	T3	3685243	57N808033MT	ALTIN-MT	71,20	T3
2605594	47N016006LT	TIALN-LT	197,50	T3	3524671	57N808033MW	ALTIN-MW	72,60	T3
2605595	47N020007LT	TIALN-LT	288,50	T3	3524672	57N808053MW	ALTIN-MW	72,60	T3
3524587	577704002MT	ALTIN-MT	47,45	T3	3524632	57N810004MT	ALTIN-MT	83,10	T3
3524611	577704002MW	ALTIN-MW	48,40	T3	3524643	57N810024MT	ALTIN-MT	95,60	T3
3524586	577704012MT	ALTIN-MT	41,25	T3	3524683	57N810024MW	ALTIN-MW	97,50	T3
3524588	577705002MT	ALTIN-MT	47,45	T3	3524644	57N810034MT	ALTIN-MT	95,60	T3
3524612	577705002MW	ALTIN-MW	48,40	T3	3524684	57N810034MW	ALTIN-MW	97,50	T3
3524590	577706002MT	ALTIN-MT	47,45	T3	3524645	57N810054MT	ALTIN-MT	95,60	T3
3524613	577706002MW	ALTIN-MW	48,40	T3	3524685	57N810054MW	ALTIN-MW	97,50	T3
3524589	577706012MT	ALTIN-MT	41,25	T3	3524646	57N812005MT	ALTIN-MT	112,50	T3
3524591	577707003MT	ALTIN-MT	57,50	T3	3524647	57N812025MT	ALTIN-MT	129,50	T3
3524614	577707003MW	ALTIN-MW	58,70	T3	3524686	57N812025MW	ALTIN-MW	132,00	T3
3524593	577708003MT	ALTIN-MT	57,50	T3	3524648	57N812035MT	ALTIN-MT	129,50	T3
3524615	577708003MW	ALTIN-MW	58,70	T3	3524687	57N812035MW	ALTIN-MW	132,00	T3
3524592	577708013MT	ALTIN-MT	50,00	T3	3524649	57N812055MT	ALTIN-MT	129,50	T3
3524594	577709004MT	ALTIN-MT	86,30	T3	3524688	57N812055MW	ALTIN-MW	132,00	T3
3524616	577709004MW	ALTIN-MW	88,00	T3	3524650	57N816006MT	ALTIN-MT	174,50	T3

Prices are valid starting January 1, 2015.

Order Number	Description	Grade	Price (€)	Group Discount	Order Number	Description	Grade	Price (€)	Group Discount
3524651	57N816026MT	ALTIN-MT	200,50	T3	5356428	57NE12025MV	ALTIN-MV	136,00	T3
3562867	57N816026MW	ALTIN-MW	204,50	T3	5356425	57NE12025MW	ALTIN-MW	132,00	T3
3524652	57N816036MT	ALTIN-MT	200,50	T3	5356429	57NE12035MV	ALTIN-MV	136,00	T3
3524689	57N816036MW	ALTIN-MW	204,50	T3	5356426	57NE12035MW	ALTIN-MW	132,00	T3
3524653	57N816056MT	ALTIN-MT	200,50	T3	5356440	57NE12055MV	ALTIN-MV	136,00	T3
3524691	57N816056MW	ALTIN-MW	204,50	T3	5356427	57NE12055MW	ALTIN-MW	132,00	T3
3524654	57N816076MT	ALTIN-MT	200,50	T3	5356444	57NE16006MV	ALTIN-MV	183,00	T3
3524692	57N816076MW	ALTIN-MW	204,50	T3	5356448	57NE16026MV	ALTIN-MV	210,50	T3
3524655	57N820007MT	ALTIN-MT	288,00	T3	5356445	57NE16026MW	ALTIN-MW	204,50	T3
3524656	57N820027MT	ALTIN-MT	331,00	T3	5356449	57NE16036MV	ALTIN-MV	210,50	T3
3524693	57N820027MW	ALTIN-MW	337,50	T3	5356446	57NE16036MW	ALTIN-MW	204,50	T3
3524657	57N820037MT	ALTIN-MT	331,00	T3	5356450	57NE16056MV	ALTIN-MV	210,50	T3
3524694	57N820037MW	ALTIN-MW	337,50	T3	5356447	57NE16056MW	ALTIN-MW	204,50	T3
3524658	57N820057MT	ALTIN-MT	331,00	T3	5350932	57NE20007MV	ALTIN-MV	302,50	T3
3524695	57N820057MW	ALTIN-MW	337,50	T3	5350933	57NE20027MV	ALTIN-MV	347,50	T3
3524659	57N820077MT	ALTIN-MT	331,00	T3	5350868	57NE20027MW	ALTIN-MW	337,50	T3
3524696	57N820077MW	ALTIN-MW	337,50	T3	5350934	57NE20037MV	ALTIN-MV	347,50	T3
3524660	57N820087MT	ALTIN-MT	331,00	T3	5350869	57NE20037MW	ALTIN-MW	337,50	T3
3524697	57N820087MW	ALTIN-MW	337,50	T3	5350935	57NE20057MV	ALTIN-MV	347,50	T3
3524661	57N825008MT	ALTIN-MT	418,50	T3	5350930	57NE20057MW	ALTIN-MW	337,50	T3
3524662	57N825028MT	ALTIN-MT	481,00	T3	5350936	57NE20087MV	ALTIN-MV	347,50	T3
3524698	57N825028MW	ALTIN-MW	490,50	T3	5350931	57NE20087MW	ALTIN-MW	337,50	T3
3524663	57N825038MT	ALTIN-MT	481,00	T3	5350953	57NE25008MV	ALTIN-MV	439,50	T3
3524699	57N825038MW	ALTIN-MW	490,50	T3	5350954	57NE25028MV	ALTIN-MV	505,00	T3
3524664	57N825058MT	ALTIN-MT	481,00	T3	5350939	57NE25028MW	ALTIN-MW	490,50	T3
3524700	57N825058MW	ALTIN-MW	490,50	T3	5350955	57NE25038MV	ALTIN-MV	505,00	T3
3524665	57N825078MT	ALTIN-MT	481,00	T3	5350950	57NE25038MW	ALTIN-MW	490,50	T3
3524701	57N825078MW	ALTIN-MW	490,50	T3	5350956	57NE25058MV	ALTIN-MV	505,00	T3
3524666	57N825088MT	ALTIN-MT	481,00	T3	5350951	57NE25058MW	ALTIN-MW	490,50	T3
3524702	57N825088MW	ALTIN-MW	490,50	T3	5350957	57NE25088MV	ALTIN-MV	505,00	T3
5356393	577E10004MT	ALTIN-MT	69,30	T3	5350952	57NE25088MW	ALTIN-MW	490,50	T3
5356391	577E10024MT	ALTIN-MT	79,60	T3	5096566	571806002MT	ALTIN-MT	46,15	T3
5356392	577E10024MW	ALTIN-MW	81,20	T3	5096567	571806012MT	ALTIN-MT	53,10	T3
5356421	577E12005MV	ALTIN-MV	98,60	T3	5096568	571806022MT	ALTIN-MT	53,10	T3
5356423	577E12015MV	ALTIN-MV	113,50	T3	5096569	571808003MT	ALTIN-MT	51,60	T3
5356422	577E12015MW	ALTIN-MW	110,00	T3	5096660	571808013MT	ALTIN-MT	59,30	T3
5356441	577E16006MV	ALTIN-MV	152,50	T3	5096661	571808023MT	ALTIN-MT	59,30	T3
5356443	577E16016MV	ALTIN-MV	175,50	T3	4124297	571810004MT	ALTIN-MT	77,30	T3
5356442	577E16016MW	ALTIN-MW	170,50	T3	5096662	571810014MT	ALTIN-MT	88,90	T3
5350866	577E20007MV	ALTIN-MV	219,00	T3	5096663	571810024MT	—	88,90	T3
5350867	577E20017MV	ALTIN-MV	252,00	T3	5096664	571810034MT	ALTIN-MT	88,90	T3
5350865	577E20017MW	ALTIN-MW	244,50	T3	5096665	571810044MT	ALTIN-MT	88,90	T3
5350938	577E25018MV	ALTIN-MV	370,50	T3	4124298	571812005MT	ALTIN-MT	105,00	T3
5350937	577E25018MW	ALTIN-MW	360,00	T3	5096666	571812015MT	—	120,50	T3
5356397	57NE10004MT	ALTIN-MT	83,10	T3	5096667	571812025MT	ALTIN-MT	120,50	T3
5356394	57NE10024MT	ALTIN-MT	95,60	T3	5096668	571812035MT	ALTIN-MT	120,50	T3
5356398	57NE10024MW	ALTIN-MW	97,50	T3	5096669	571812045MT	ALTIN-MT	120,50	T3
5356395	57NE10034MT	ALTIN-MT	95,60	T3	4124299	571814014MT	ALTIN-MT	143,50	T3
5356399	57NE10034MW	ALTIN-MW	97,50	T3	5096752	571814024MT	ALTIN-MT	165,00	T3
5356396	57NE10054MT	ALTIN-MT	95,60	T3	5096753	571814034MT	ALTIN-MT	165,00	T3
5356420	57NE10054MW	ALTIN-MW	97,50	T3	5096754	571814044MT	ALTIN-MT	165,00	T3
5356424	57NE12005MV	ALTIN-MV	118,50	T3	5096755	571814054MT	ALTIN-MT	165,00	T3

Prices are valid starting January 1, 2015.

Order Number	Description	Grade	Price (€)	Group Discount	Order Number	Description	Grade	Price (€)	Group Discount
4124300	571816006MT	ALTIN-MT	164,00	T3	5090269	BT40BSFTT25085M	—	212,00	NO
5096756	571816016MT	ALTIN-MT	189,00	T3	5090270	BT40BSFTT32085M	—	212,00	NO
5096757	571816026MT	ALTIN-MT	189,00	T3	5090277	BT50BSFTT12100M	—	429,50	NO
5096758	571816036MT	ALTIN-MT	189,00	T3	5090278	BT50BSFTT14100M	—	429,50	NO
5096759	571816046MT	ALTIN-MT	189,00	T3	5090279	BT50BSFTT16100M	—	429,50	NO
5096800	571816056MT	ALTIN-MT	189,00	T3	5090280	BT50BSFTT18100M	—	429,50	NO
4124301	571818018MT	ALTIN-MT	243,50	T3	5090281	BT50BSFTT20100M	—	429,50	NO
5096801	571818028MT	ALTIN-MT	280,00	T3	5090282	BT50BSFTT25100M	—	429,50	NO
5096802	571818038MT	ALTIN-MT	280,00	T3	5090239	DV40BSFTT16065M	—	212,00	NO
5096803	571818048MT	ALTIN-MT	280,00	T3	5090260	DV40BSFTT18065M	—	212,00	NO
5096804	571818058MT	ALTIN-MT	280,00	T3	5090261	DV40BSFTT20065M	—	212,00	NO
4124302	571820007MT	ALTIN-MT	250,50	T3	5090262	DV40BSFTT25075M	—	212,00	NO
5096805	571820017MT	ALTIN-MT	288,00	T3	5090263	DV40BSFTT32080M	—	212,00	NO
5096806	571820027MT	ALTIN-MT	288,00	T3	5129969	DV40BSFTT12065M	—	212,00	NO
5096807	571820037MT	ALTIN-MT	288,00	T3	5129970	DV40BSFTT14065M	—	212,00	NO
5096808	571820047MT	ALTIN-MT	288,00	T3	5090271	DV50BSFTT12080M	—	429,50	NO
5096809	571820057MT	ALTIN-MT	288,00	T3	5090272	DV50BSFTT14080M	—	429,50	NO
4124323	571825008MT	ALTIN-MT	418,50	T3	5090273	DV50BSFTT16080M	—	429,50	NO
5096860	571825018MT	ALTIN-MT	481,00	T3	5090274	DV50BSFTT18080M	—	429,50	NO
5096861	571825028MT	ALTIN-MT	481,00	T3	5090275	DV50BSFTT20080M	—	429,50	NO
5096862	571825038MT	ALTIN-MT	481,00	T3	5090276	DV50BSFTT25100M	—	429,50	NO
5096863	571825048MT	ALTIN-MT	481,00	T3	5090212	HSK100ASFHDTT16100M	—	566,00	NO
5096864	571825058MT	ALTIN-MT	481,00	T3	5090213	HSK100ASFHDTT20100M	—	566,00	NO
3474583	49N604002MW	ALTIN-MW	82,40	T2	5090214	HSK100ASFHDTT25110M	—	566,00	NO
3474584	49N605002MW	ALTIN-MW	82,40	T2	5090215	HSK100ASFHDTT32110M	—	566,00	NO
3474585	49N606002MW	ALTIN-MW	82,40	T2	5090216	HSK100ASFHDTT40140M	—	566,00	NO
3474587	49N608003MW	ALTIN-MW	96,50	T2	5090217	HSK100ASFHDTT50140M	—	566,00	NO
3474589	49N610004MW	ALTIN-MW	122,00	T2	5520977	HSK100AHCTHT32100M	—	513,00	NO
3474591	49N612005MW	ALTIN-MW	142,00	T2	5520976	HSK100AHCTHT20090M	—	503,00	NO
3474593	49N614014MW	ALTIN-MW	169,00	T2	5520974	DV50HCTHT32080M	—	482,50	NO
3474594	49N616006MW	ALTIN-MW	202,50	T2	5520973	DV40HCTHT20070M	—	340,50	NO
3474595	49N618018MW	ALTIN-MW	230,50	T2	3026651	20MHC060M	—	81,90	NO
3474596	49N620007MW	ALTIN-MW	282,00	T2	3026653	20MHC080M	—	81,90	NO
3474597	49N625008MW	ALTIN-MW	388,00	T2	3026657	20MHC120M	—	81,90	NO
5090218	HSK63ASFTT12070M	—	229,00	NO	3026659	20MHC140M	—	81,90	NO
5090219	HSK63ASFTT14075M	—	229,00	NO	3026661	20MHC160M	—	81,90	NO
5090220	HSK63ASFTT16075M	—	229,00	NO	3026675	32MHC060M	—	104,00	NO
5090221	HSK63ASFTT18075M	—	229,00	NO	3026677	32MHC080M	—	104,00	NO
5090222	HSK63ASFTT20075M	—	229,00	NO	3026681	32MHC120M	—	104,00	NO
5090223	HSK63ASFTT25085M	—	229,00	NO	3026683	32MHC140M	—	104,00	NO
5090224	HSK63ASFTT32085M	—	229,00	NO	3026685	32MHC160M	—	104,00	NO
5090056	HSK100ASFTT12095M	—	446,50	NO	3026687	32MHC180M	—	104,00	NO
5090057	HSK100ASFTT14095M	—	446,50	NO	3026688	32MHC200M	—	104,00	NO
5090058	HSK100ASFTT16100M	—	446,50	NO	3026690	32MHC250M	—	104,00	NO
5090059	HSK100ASFTT18100M	—	446,50	NO					
5090210	HSK100ASFTT20105M	—	446,50	NO					
5090211	HSK100ASFTT25115M	—	446,50	NO					
5090264	BT40BSFTT12070M	—	212,00	NO					
5090265	BT40BSFTT14075M	—	212,00	NO					
5090266	BT40BSFTT16075M	—	212,00	NO					
5090267	BT40BSFTT18075M	—	212,00	NO					
5090268	BT40BSFTT20075M	—	212,00	NO					

Prices are valid starting January 1, 2015.

Solid End Milling Icons

Plunge Milling	Ramping: Blank	Slotting: Ball Nose	Side Milling/Shoulder Milling: Square End	Side Milling/Shoulder Milling: Ball Nose
Side Milling/Shoulder Milling: Square End	Trochoidal Milling	3D Profiling	Corner Style: Ball Nose	Corner Style: Corner Chamfer
Corner Style: Radius	Corner Style: Square End	Helix Angle: 43°	Helix Angle: 30°	Helix Angle: 38°
Tool Dimensions: Flute Configuration: X	Tool Dimensions: Flute Configuration: 4	Tool Dimensions: Flute Configuration: 5		

Tooling Systems Icons

Shank: Cylindrical Plain ≤H6	Shank: HSK A/DIN	Shank: HSK A/DIN 69893	Shank: KM-TS™ (ISO 26622)	Shank: KM4X™
Shank: SAFE-LOCK™ h6	SK BT (MAS-403-BT)	Shank: SK DV (DIN 69871)	Shank: SK	Axial Adjustments: End
Balance: G 2.5@ 25,000	Speed 30,000 min ⁻¹ Maximum	Accuracy: 3µm or Less	Through Coolant: 100 bar	Through Coolant: 1500 psi
Through Adaptor Face				

DIN – German Institute for Standardisation

Material Group	Description	Content	Tensile Strength RM (MPa)*	Hardness (HB)	Hardness (HRC)	DIN Standards
P1	Low-Carbon Steels, Long Chipping	C <.25%	<530	<125	–	P St 37-3, C 15, GS-38 Cq10
P2	Low-Carbon Steels, Free Machining, Short Chipping	C <.25%	<650	<220	<25	33 Mn 6, 9 SMn 28, 20 Mn 5, 17 Cr 3
P3	Medium-, High-Plain Carbon Steels, Low-Alloyed	C >.25%	600–850	<330	<35	C 75, Ck 45, C 70 W1, 90 MnCrV 8, 42 CrMo 4 16MnCr5, ST52
P4	Alloyed, Tempered Carbon Steels, Tool	C >.25 %	800–1100	350–450	35–48	100 Cr 6, 105 MnCr4, 51 CrMnV 4, 105 WCr 6, 100 Cr 2
P5	Ferritic, Martensitic, PH Stainless Steels	C = 0–.4%	600–850	<330	<35	X 6 Cr 13, X 10 Cr 13, X 20 Cr 13, X 12 CrMoS 17, X 20 CrMo 13
P6	High-Strength Ferritic, Martensitic, PH Stainless Steels	C = .1–.6%	900–1350	350–450	35–48	X 40 CrMoV 5 1, H1, X 155 CrVMo 12 1, S 6-5-2-5, X 45 Cr 13, X 120 Mn12
M1	Austenitic Stainless Steel	C = .05–.15%	<650	130–200	–	X 5 CrNi 18 10, GX 6 CrNiMo 18 10, X 6 CrNiMoTi 17 12 2, X 8 CrNiMoAl 15 7 2
M2	High-Strength Austenitic Stainless, Cast Stainless Steels	C = .05–.15%	500–700	150–230	<25	X 2 CrNiMo 13 4, X 10 CrNi18 9, X 5 CrNiCuNb 17 4 4
M3	Duplex Steel	C = .05–.2%	<900	135–275	<30	X 2 CrNiMoN 23 15, X 20 CrNiSi 25 4, GX 40 CrNiSi 27 4, X 2 CrNiMoN 22 5 3
K1	Grey Cast, Low-Strength Ductile Irons	–	150–400	120–290	<32	GG-10, GG-15, GG-20, GG -25, GG- 40
K2	Low-, Medium-Strength CGI, Ductile Irons	–	400–600	130–260	<28	GGG-35.3, GGG- 40.3, GGG-70
K3	High-Strength Ductile, Austempered Ductile Iron	–	600–900	180–350	<38	GTW-35-04, GTW-65, GTS-35-10, GTS-45-06
N1	Wrought Aluminium Alloys	–	<520	60–90	–	Al99.5, AlCuMgPb, AlMg 1, SG-AlMg 5
N2	Cast Aluminium	Si <12.2%	<350	70–100	–	G-AISI 9 Mg, G-AISI 10 Mg, G-AISI 10 Mg(Cu), SG-AISI 12, G-AISI 7 Mg
N3	Cast Aluminiums	Si >12.2%	200–320	60–120	–	G-AISI17Cu4Mg, GK-AISI18CuNiMg, GK-AISI21CuNiMg
N4	MMCs (Aluminium-Based Metal Matrix)	–	<700	210	–	GFK, CFK
N5	Copper, Copper Alloys	–	200–650	60–200	–	CuZn 20, CuSn 2, CuNi 18 Zn 19 Pb
N6	Carbon, Graphite Composites	–	600–1500	–	–	Graphite, CFK, CFRP
S1	Iron-Based, Heat-Resistant Alloys	–	500–1200	160–260	–	X 2 NiCrAlTi 32 20, X 1 NiCrMoCu 32 28 7, X 12 NiCr 36 18, x 12 NiCrSi 35 16
S2	Nickel-Based or Cobalt-Based, Heat-Resistant Alloys	–	1000–1450	250–450	25–48	X 12 CrNiMn 18 88, Alloy 222 (Ni99,7Mg0,07), NiCr 20 Mo, NiCr 19 FeNbMo
S3	Titanium	–	900–1600	300–400	33–43	Ti 3, Ti 4, TiAl 3 V2.5
S4	Titanium Alloys	–	900–1600	300–400	33–43	TiAl 5 Fe 2.5, TiAl 6 V 4, TiAl 4 Mo 4 Sn 2
H1	Hardened Steels, Irons	–	–	<460	<48	–
H1	Hardened Steels, Irons	–	–	460–560	48–55	–
H2	Hardened Steels, Irons	–	–	560–650	56–60	–
H4	Hardened Steels, Irons	–	–	>650	>60	–

* 1 MPa = 145 psi







Metalcutting Safety

IMPORTANT SAFETY INSTRUCTIONS

Read before using the tools in this catalogue!

Projectile and Fragmentation Hazards

Modern metalcutting operations involve high spindle and cutter speeds and high temperatures and cutting forces. Hot metal chips may fly off the workpiece during metalcutting. Although cutting tools are designed and manufactured to withstand high cutting forces and temperatures, they can sometimes fragment, particularly if they are subjected to over-stress, severe impact, or other abuse.

To avoid injury:

- Always wear appropriate personal protective equipment, including safety goggles, when operating metalcutting machines or working nearby.
- Always make sure all machine guards are in place.

Breathing and Skin Contact Hazards:

Grinding carbide or other advanced cutting tool materials produce dust or mist containing metallic particles. Breathing this dust or mist — especially over an extended period — can cause temporary or permanent lung disease or make existing medical conditions worse. Contact with this dust or mist can irritate eyes, skin, and mucous membranes and may make existing skin conditions worse.

To avoid injury:

- Always wear breathing protection and safety goggles when grinding.
- Provide ventilation control and collect and properly dispose of dust, mist, or sludge from grinding.
- Avoid skin contact with dust or mist.

For more information, read the applicable Material Safety Data Sheet provided by Kennametal and consult General Industry Safety and Health Regulations, Part 1910, Title 29 of the Code of Federal Regulations.

These safety instructions are general guidelines. Many variables affect machining operations. It is impossible to cover every specific situation. The technical information included in this catalogue and recommendations on machining practices may not apply to your particular operation. For more information, consult Kennametal's Metalcutting Safety booklet, available free from Kennametal at 724.539.5747 or fax 724.539.5439. For specific product safety and environmental questions, contact our Corporate Environmental Health and Safety Office at 724.539.5066 or fax 724.539.5372.

ERICKSON, HydroForce, KM4X, KM63TS, KM-TS, VariMill, VariMill I, VariMill II, Victory, Vision Plus, WIDIA, WIDIA-Hanita, WIDIA-Rubig, and X-Feed are trademarks of Kennametal, Inc. and are used as such herein. The absence of a product, service name, or logo from this list does not constitute a waiver of Kennametal's trademark or other intellectual property rights concerning that name or logo.

SAFE-TOCK™ is a trademark of Haimer GmbH.

Weldon® is a registered trademark of Weldon Tool Company.

©Copyright 2014 by Kennametal Inc., Latrobe, PA 15650. All rights reserved.

WIDIA™ Solid Carbide End Mills

High Speed Trochoidal Milling

World and Corporate Headquarters

Kennametal Inc.
WIDIA Products Group
1600 Technology Way
Latrobe, PA 15650 USA
Phone: 800 446 7738 (United States and Canada)
E-mail: w-na.service@widia.com

Asia-Pacific Headquarters

Kennametal Singapore Pte. Ltd.
WIDIA Products Group
3A International Business Park
Unit #01-02/03/05, ICON@BP
Singapore 609935
Phone: +65 6265 9222
E-mail: w-sg.service@widia.com

European Headquarters

Kennametal Europe GmbH
WIDIA Products Group
Rheingoldstrasse 50
CH 8212 Neuhausen am Rheinfall
Switzerland
Phone: +41 52 6750 100
E-mail: w-ch.service@widia.com

India Headquarters

Kennametal India Limited
WIDIA Products Group
CIN: L27109KA1964PLC001546
8/9th Mile, Tumkur Road
Bangalore - 560 073
Phone: +91 080 22198444 or +91 080 43281444
E-mail: w-in.service@widia.com

©2014 Kennametal Inc. All rights reserved. A-14-04126EN_me



WWW.WIDIA.COM